

PHRB

series

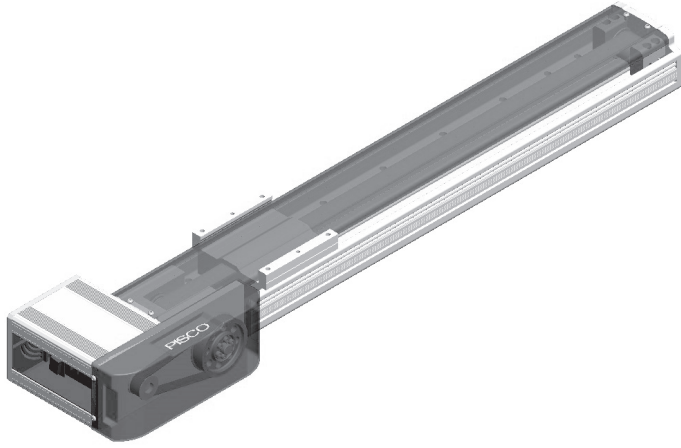

투시형 커버 (폴리 · 모터)

외장 센서 조립 가능

WIDE SLIDE 적용으로 중간 체결판 불요

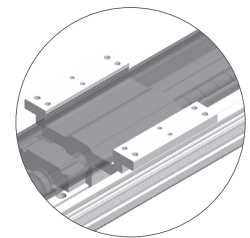

상 · 하 양방향으로 자유로운 취부 가능

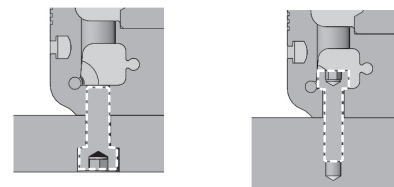

[하부에서 조립] [상부에서 조립]

PHRB Series

주문형식 Order Information

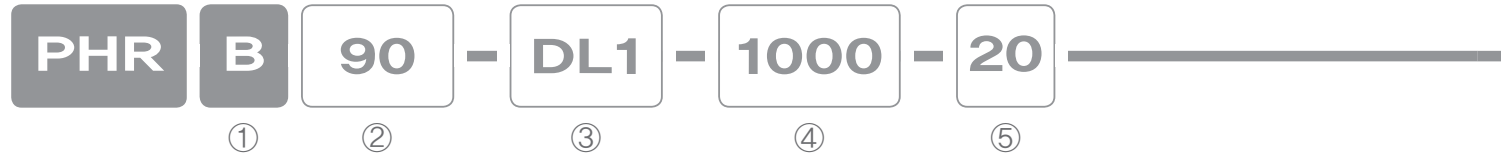

① 형식 Type

B Standard Robot, Belt Type

② 본체 사이즈 Body Size

90 90mm

③ 형상 Shape

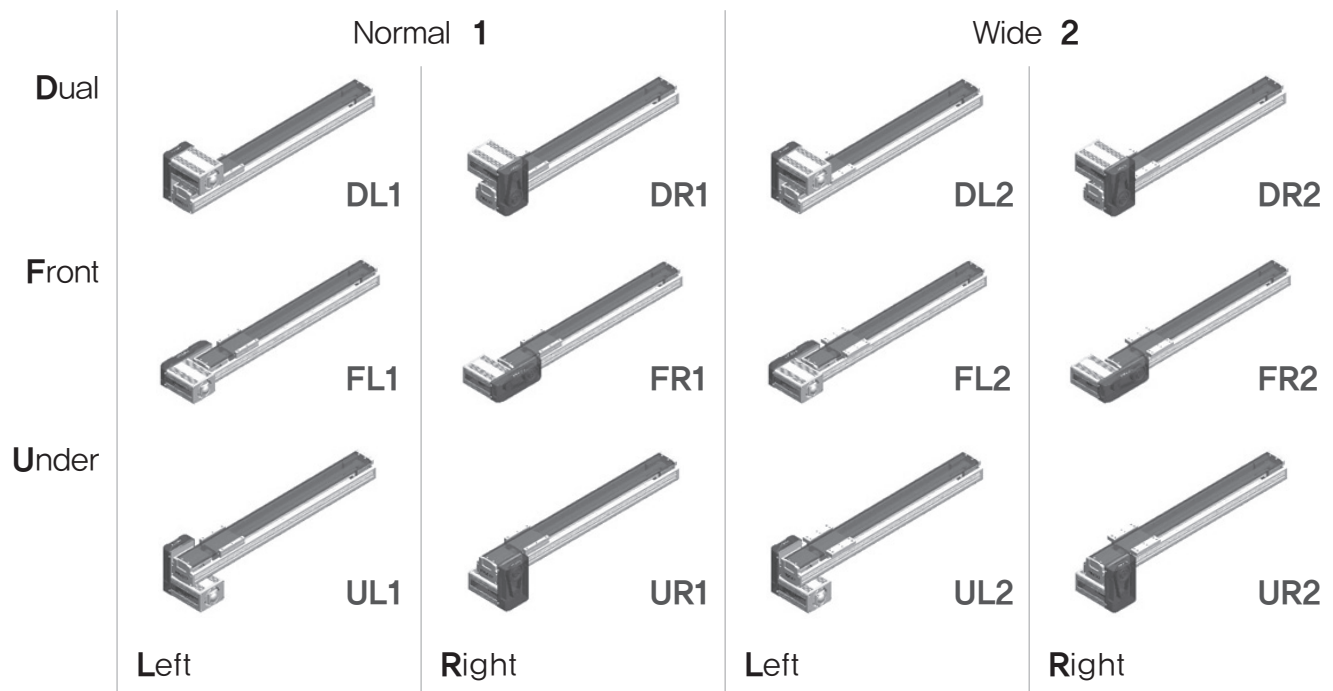

④ 이송거리 Stroke, In increment of 50mm

Max 1500 mm The Distance Between -OT and +OT (mm)

⑤ 모터용량 Motor capacity

20 200W **40** 400W

선택사양 Option



⑥ 로봇 색상 Robot Color Option

None	White (Standard)	B	Black Anodizing
-------------	------------------	----------	-----------------

⑦ 센서 Sensor

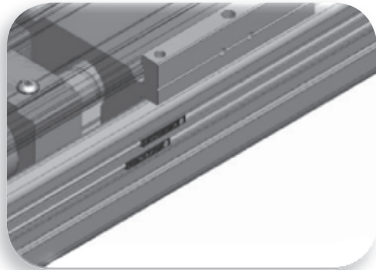

None	External DC-24V Proximity LED Sensor (Standard)
-------------	---

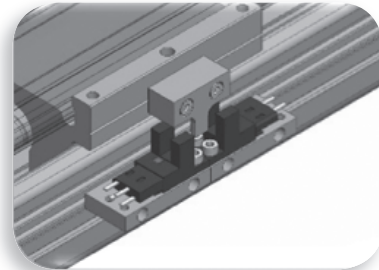

E1	SUNX (PM-Y54)
E2	OMRON (EE-SX674A)
E3	SUNX (PM-L24)

⑧ 표면처리 Surface Treatment

None	Without Surface Treatment
R1	LM Rail-Raydent
R2	LM Rail+Block-Raydent

⑨ 감속기 Reduction Gear

None	Tming Pulley Reduction
G**	With Reduction Gear
**	Reduction Gear Ratio 03~10

⑩ 케이블베어 Cableveyor

None	Without Cableveyor	C	With Cableveyor
-------------	--------------------	----------	-----------------

Standard Robot
Timing Belt Type

PHRB

사양 Specifications

공통사양 Common Specifications

Stroke Range	mm	100 ~ 1500
Positioning Repeatability		±0.1
Drive System	mm	Timing Belt
Guide		1 Way 42 – 2UU
Main Base & Slide		Aluminum Profile, Soft White Anodizing
Cover		Aluminum Profile, Soft White Anodizing
Sensor Cable Length	mm	Standard Sensor Cable Body Out 300
Driving Pulley		P.C.D Ø23.87

※ Cover에 Transparent PC Extrude Profile의 사양은 특주로 대응됩니다.

허용 이격 거리 Allowable Overhang Distance

Installation Types Load capacity		Setting Angle	Allowable Overhang Distance (mm)			
			5kg	10kg	20kg	30kg
Horizontal Use		0°	395	190	85	50
		45°	353	162	74	42
		90°	1500	760	350	210
Estimated Condition	Stroke : 1000mm Speed : 1000mm/sec Acceleration : 0.2sec Life in traveled distance : 15000km or 15000Hr					

최고속도 및 부하하중 Max Speed & Pay Load

Reduction Gear Ratio	Max Speed mm/s	Horizontal Moving AC Servo Motor Output		Remark
		200W	400W	
G06	625	30kg	30kg	
G05	750	30kg	30kg	
G04	938	30kg	30kg	
G03	1250	20kg	30kg	
None (1/2)	1875	6kg	14kg	
Estimated Condition	Stroke : 1000mm Speed : Max Speed Acceleration : 0.3sec Servo Motor Rotate : 3000rpm			

이송거리별 무게 Weight by Stroke

Motor Capacity	Stroke (mm) & Weight (kg)																			
	100	200	300	400	500	600	700	800	900	1000	1100	1200	1300	1400	1500	1600	1700	1800	1900	2000
200W	7.0	7.7	8.3	9.0	9.6	10.3	10.9	11.6	12.2	12.9	13.5	14.2	14.8	15.5	16.1					
400W	7.6	8.2	8.9	9.5	10.2	10.8	11.5	12.1	12.8	13.4	14.1	14.7	15.4	16.0	16.7					

PHRB090-DL1-20(40)

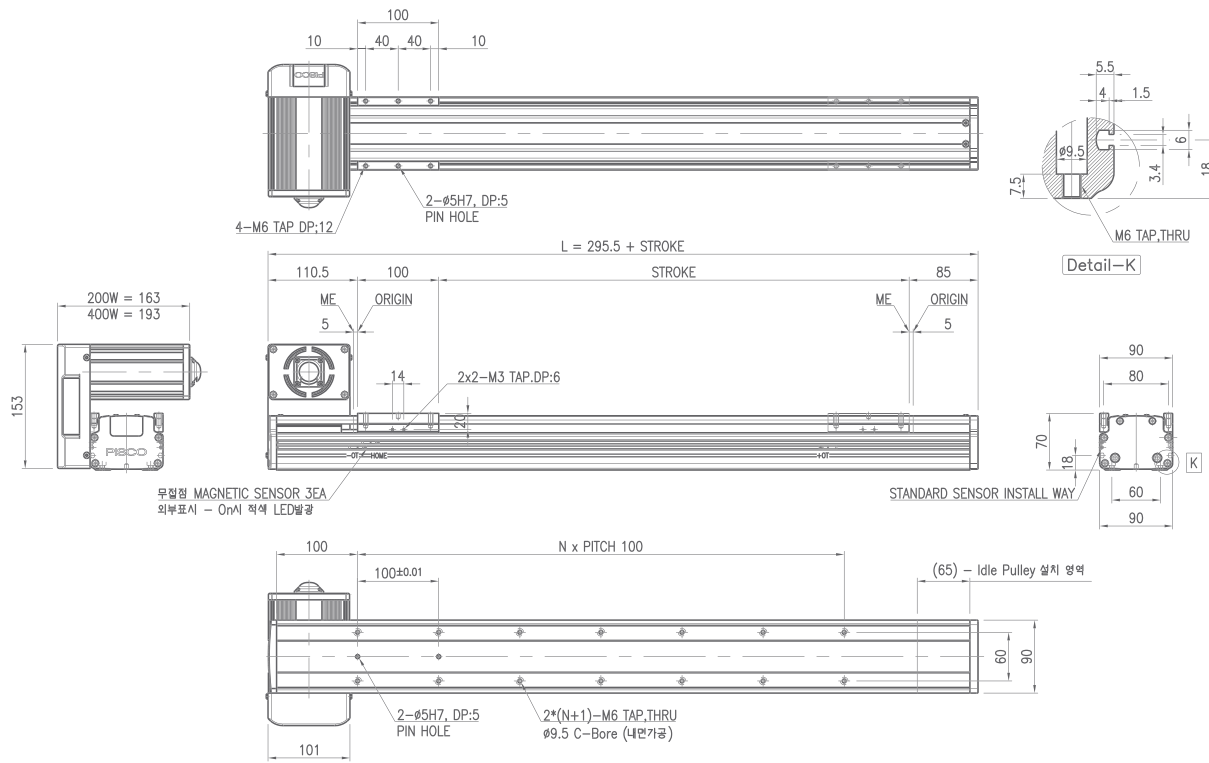

Standard Robot
Timing Belt Type

PHRB

PHRB090-DL2-20(40)

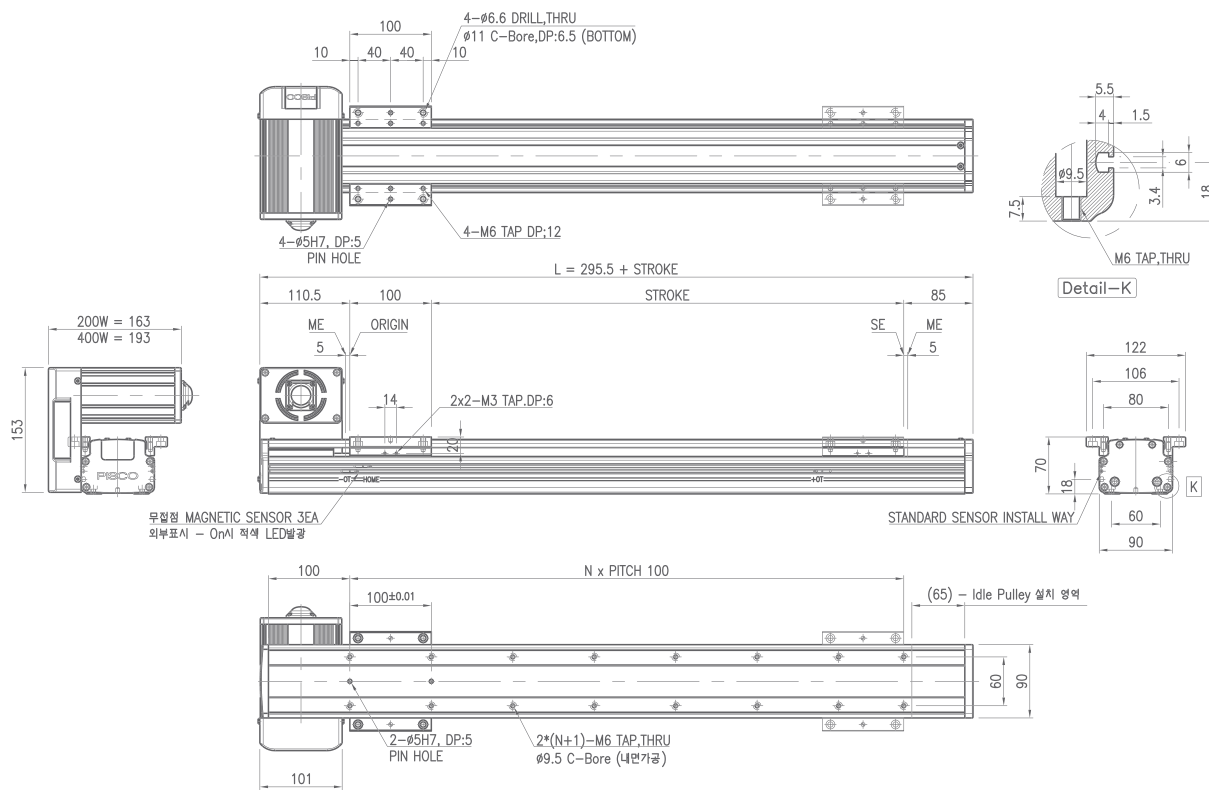

치수도 Dimension (mm)

PHRB090-DR1-20(40)

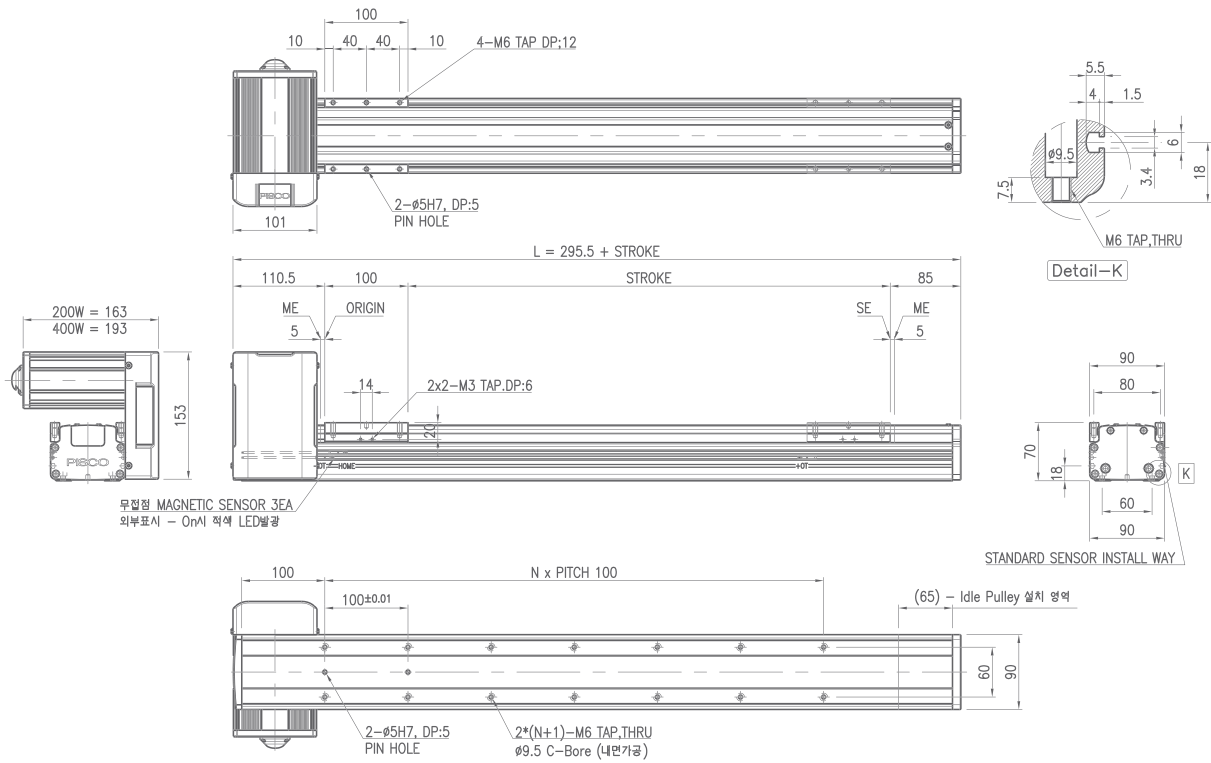

PHRB090-DR2-20(40)

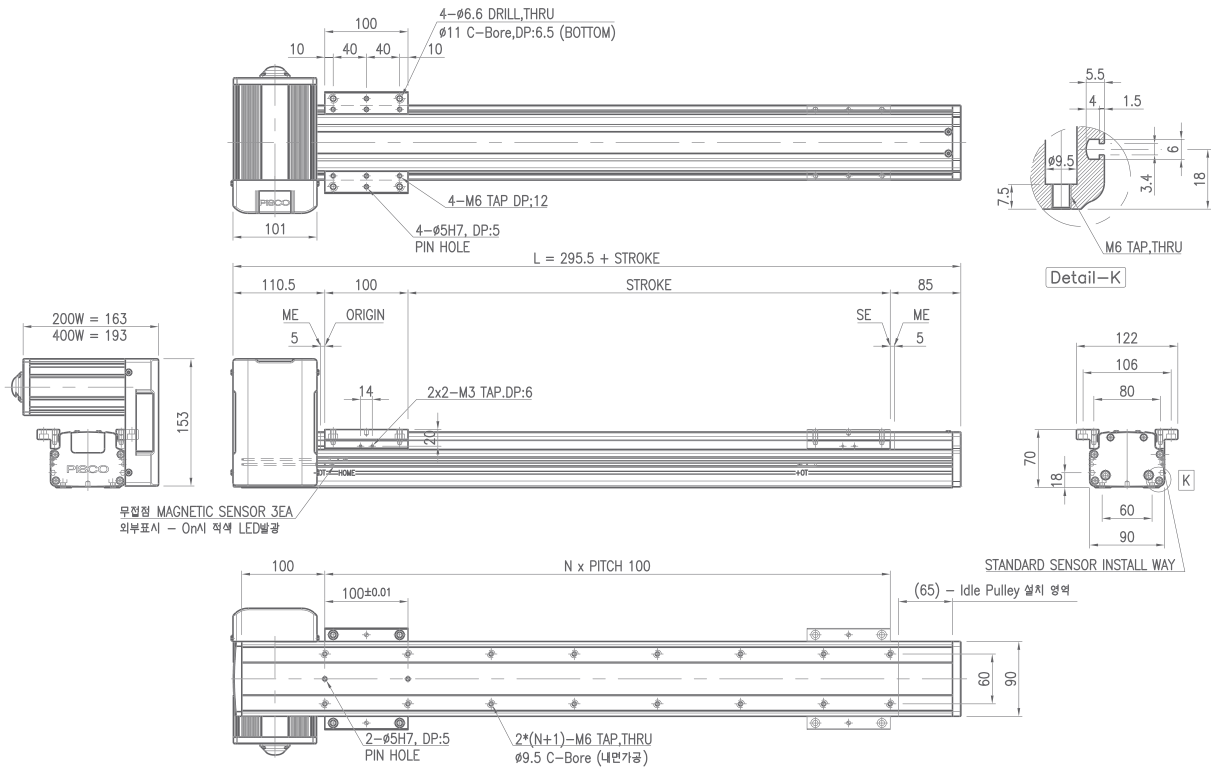

치수도 Dimension (mm)

PHRB090-FR1-20(40)

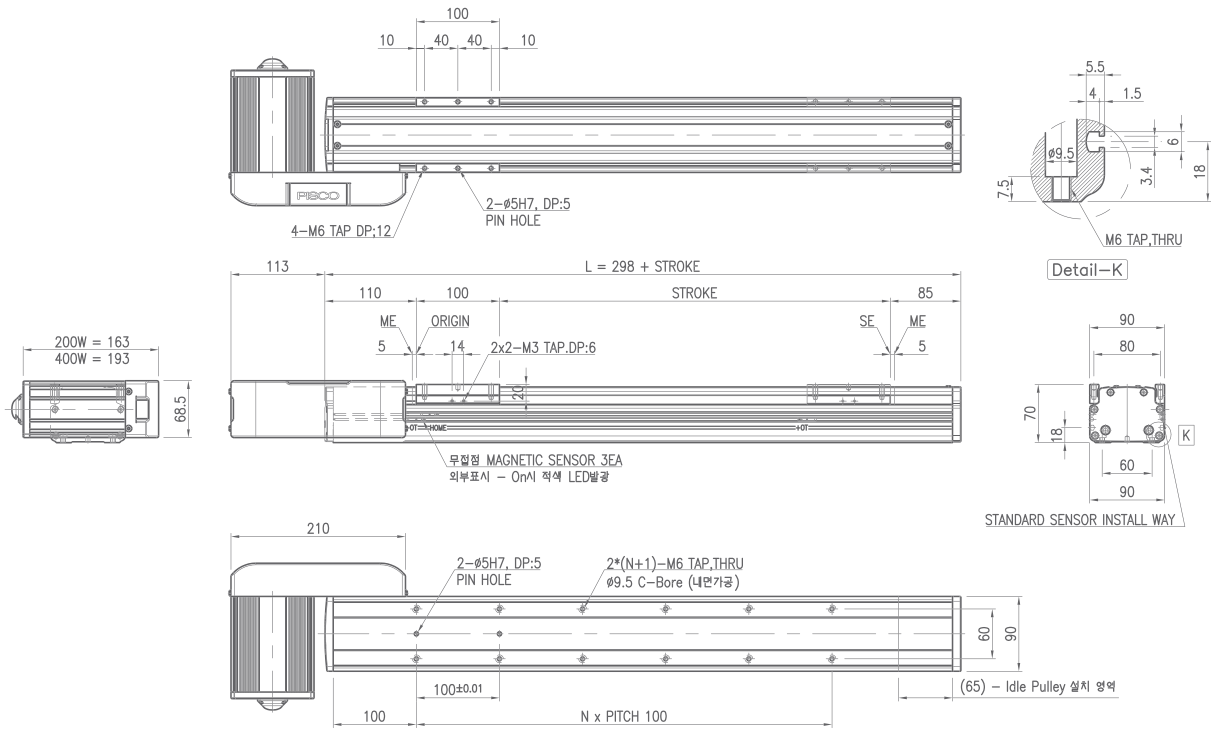

PHRB090-FR2-20(40)

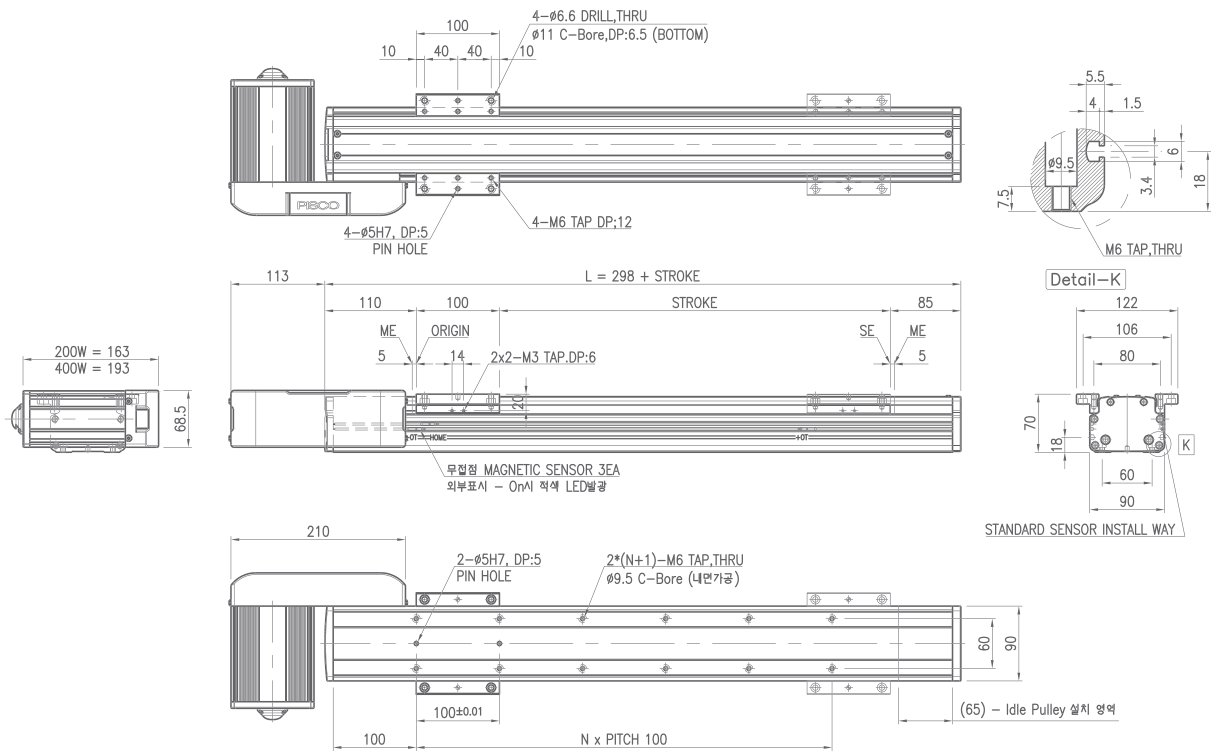

PHRB090-UL1-20(40)

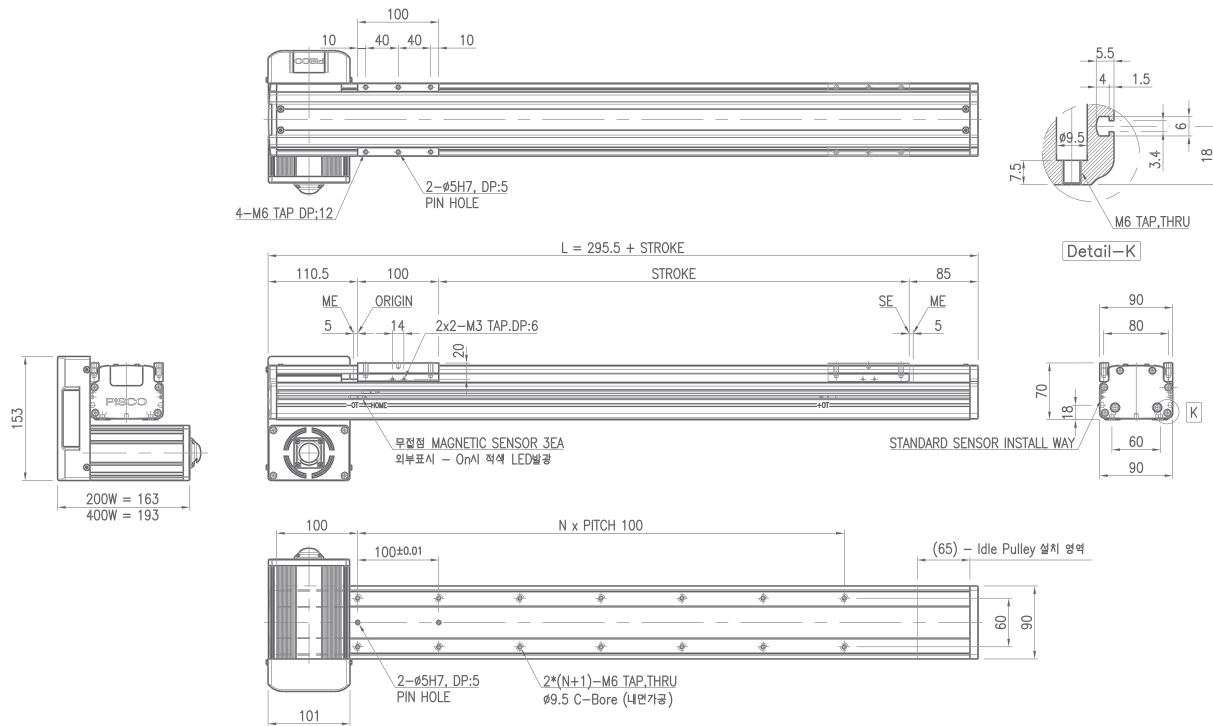

Standard Robot
Timing Belt Type

PHRB

PHRB090-UL2-20(40)

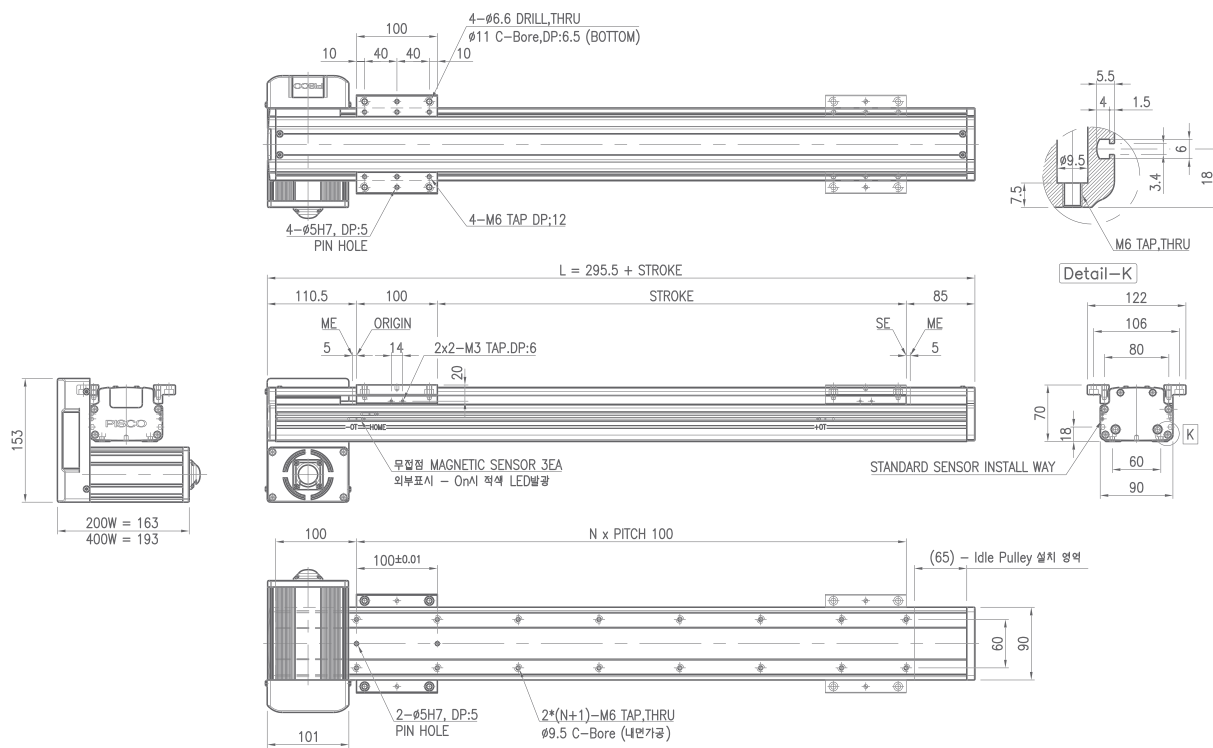

치수도 Dimension (mm)

PHRB090-UR1-20(40)

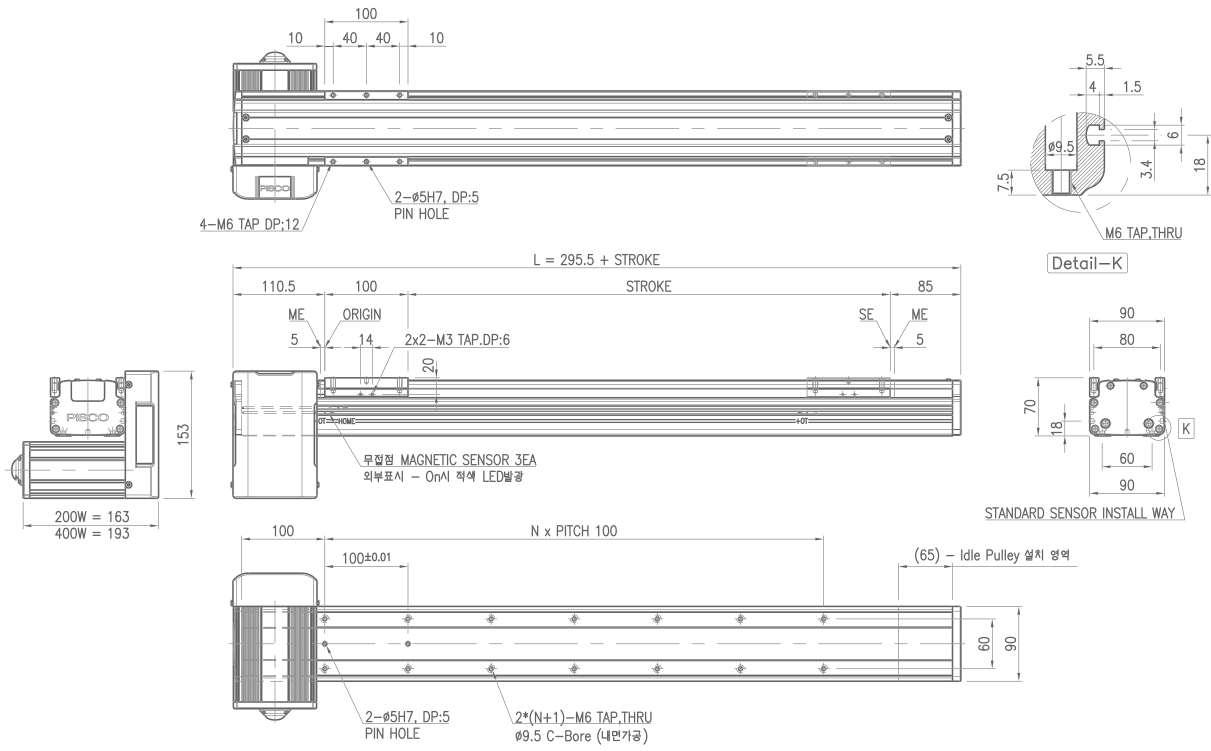

PHRB090-UR2-20(40)

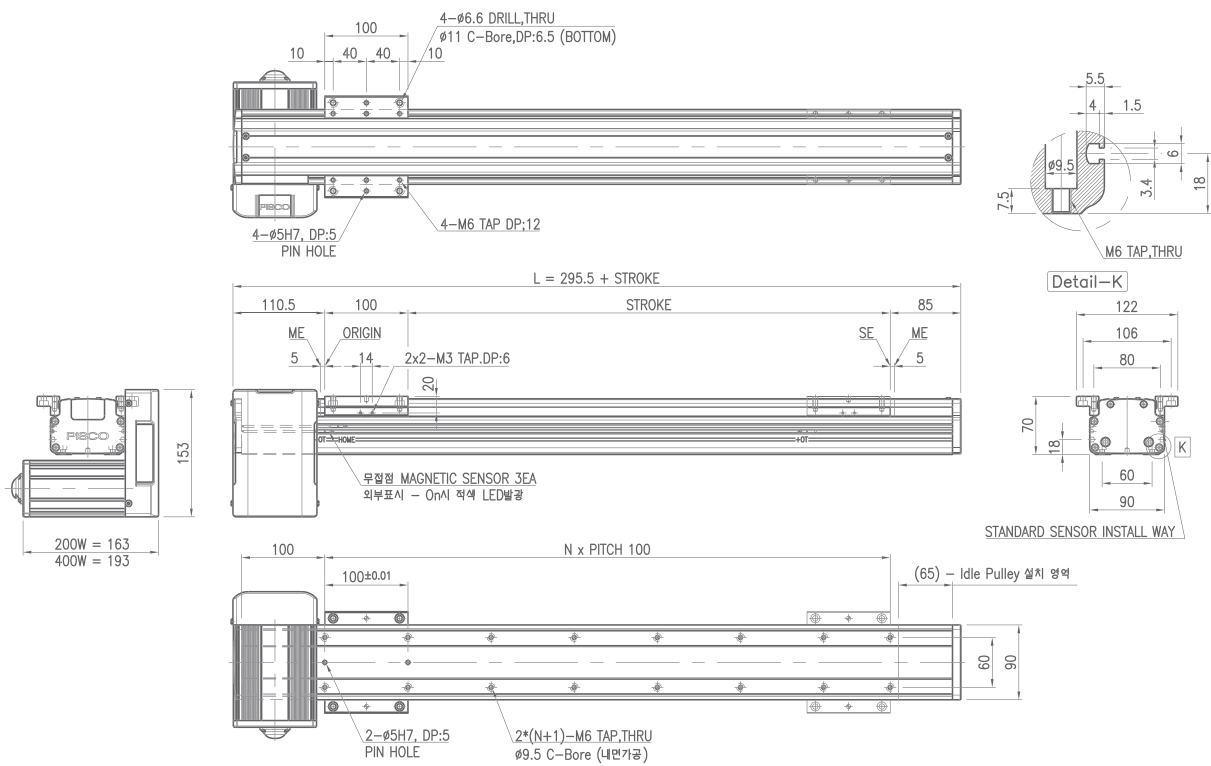

Standard Robot
Timing Belt Type

PHR B

PHRB Series

주문형식 Order Information



① 형식 Type

B Standard Robot, Belt Type

② 본체 사이즈 Body Size

120 120mm

③ 형상 Shape

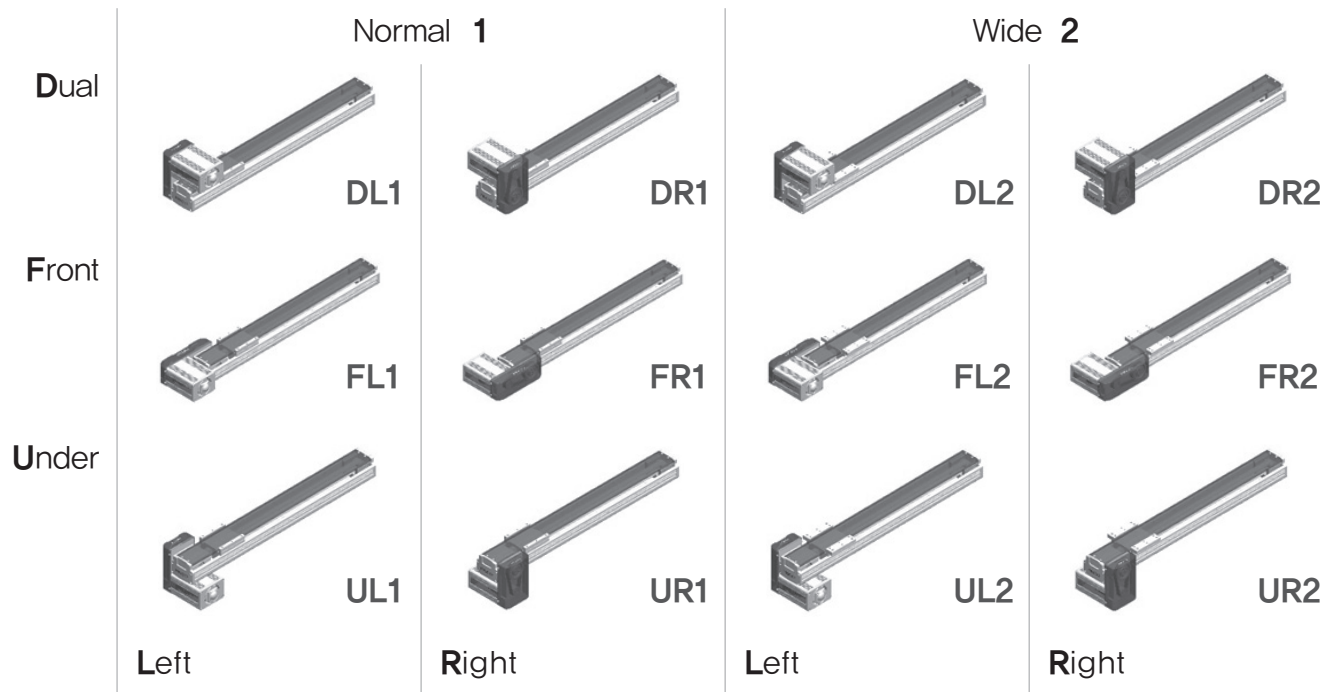

④ 이송거리 Stroke, In increment of 50mm

Max 2000 mm The Distance Between -OT and +OT (mm)

⑤ 모터용량 Motor capacity

20 200W **40** 400W **75** 750W

선택사양 Option



⑥ 로봇 색상 Robot Color Option

None	White (Standard)	B	Black Anodizing
-------------	------------------	----------	-----------------

⑦ 센서 Sensor

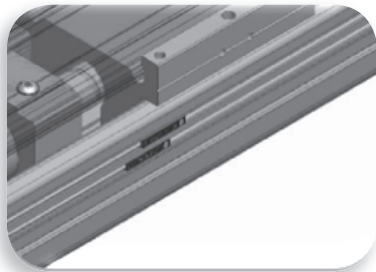

None	External DC-24V Proximity LED Sensor (Standard)
-------------	---

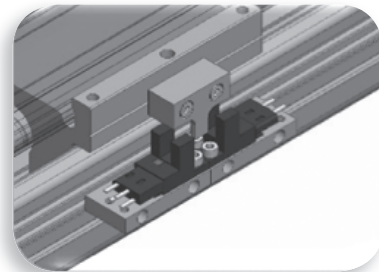

E1	SUNX (PM-Y54)
E2	OMRON (EE-SX674A)
E3	SUNX (PM-L24)

⑧ 표면처리 Surface Treatment

None	Without Surface Treatment
R1	LM Rail-Raydent
R2	LM Rail+Block-Raydent

⑨ 감속기 Reduction Gear

None	Tming Pulley Reduction
G**	With Reduction Gear
**	Reduction Gear Ratio 03~10

⑩ 케이블베어 Cableveyor

None	Without Cableveyor	C	With Cableveyor
-------------	--------------------	----------	-----------------

Standard Robot
Timing Belt Type

PHRB

사양 Specifications

공통사양 Common Specifications

Stroke Range	mm	100 ~ 2000
Positioning Repeatability		±0.1
Drive System	mm	Timing Belt
Guide		2 Way 15W – 2UU
Main Base & Slide		Aluminum Profile, Soft White Anodizing
Cover		Aluminum Profile, Soft White Anodizing
Sensor Cable Length	mm	Standard Sensor Cable Body Out 300
Driving Pulley		P.C.D Ø33.42

※ Cover에 Transparent PC Extrude Profile의 사양은 특주로 대응됩니다.

허용 이격 거리 Allowable Overhang Distance

Installation Types Load capacity		Setting Angle	Allowable Overhang Distance (mm)			
			20kg	30kg	40kg	50kg
Horizontal Use		0°	380	260	200	165
		45°	318	215	166	134
		90°	900	900	700	570
Estimated Condition	Stroke : 1000mm Speed : 1000mm/sec Acceleration : 0.2sec Life in traveled distance : 15000km or 15000Hr					

최고속도 및 부하하중 Max Speed & Pay Load

Reduction Gear Ratio	Max Speed mm/s	Horizontal Moving AC Servo Motor Output			Remark
		200W	400W	750W	
G06	875	41kg	50kg	50kg	
G05	1050	27kg	50kg	50kg	
G04	1313	16kg	31kg	50kg	
G03	1750	7kg	16kg	50kg	
None (1/2.5)	2072	4kg	9kg	–	200W, 400W
None (1/2)	2625	–	–	25kg	750W
Estimated Condition	Stroke : 1000mm Speed : Max Speed Acceleration : 0.3sec Servo Motor Rotate : 3000rpm				

이송거리별 무게 Weight by Stroke

Motor Capacity	Stroke (mm) & Weight (kg)																								
	100	200	300	400	500	600	700	800	900	1000	1100	1200	1300	1400	1500	1600	1700	1800	1900	2000	2100	2200	2300	2400	2500
200W	10.5	11.3	12.1	13.0	13.8	14.6	15.5	16.3	17.1	18.0	18.8	19.6	20.5	21.3	22.1	23.0	23.8	24.6	25.5	26.3					
400W	11.0	11.9	12.7	13.5	14.4	15.2	16.0	16.9	17.7	18.5	19.4	20.2	21.0	21.9	22.7	23.5	24.4	25.2	26.0	26.9					
750W	12.5	13.3	14.1	15.0	15.8	16.6	17.5	18.3	19.1	20.0	20.8	21.6	22.5	23.3	24.1	25.0	25.8	26.6	27.5	28.3					

PHRB120-DL1-40(75)

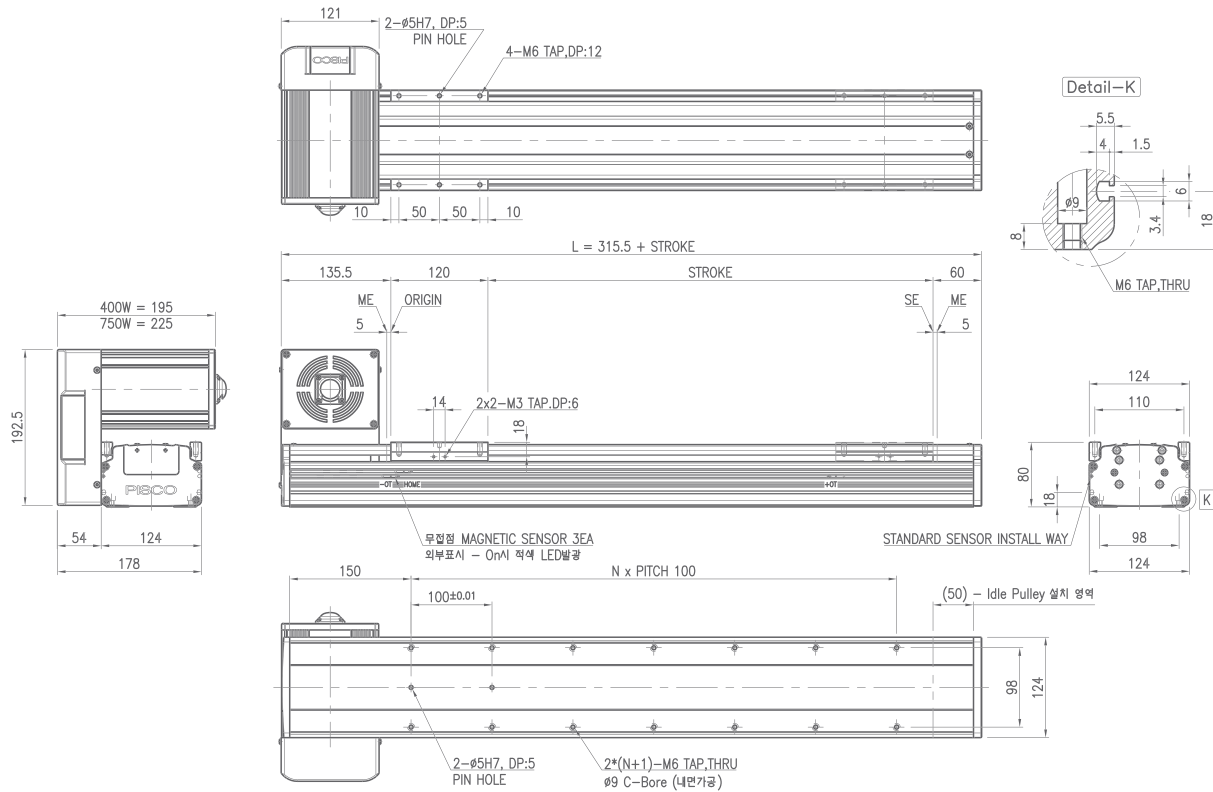

Standard Robot
Timing Belt Type

PHRB

PHRB120-DL2-40(75)

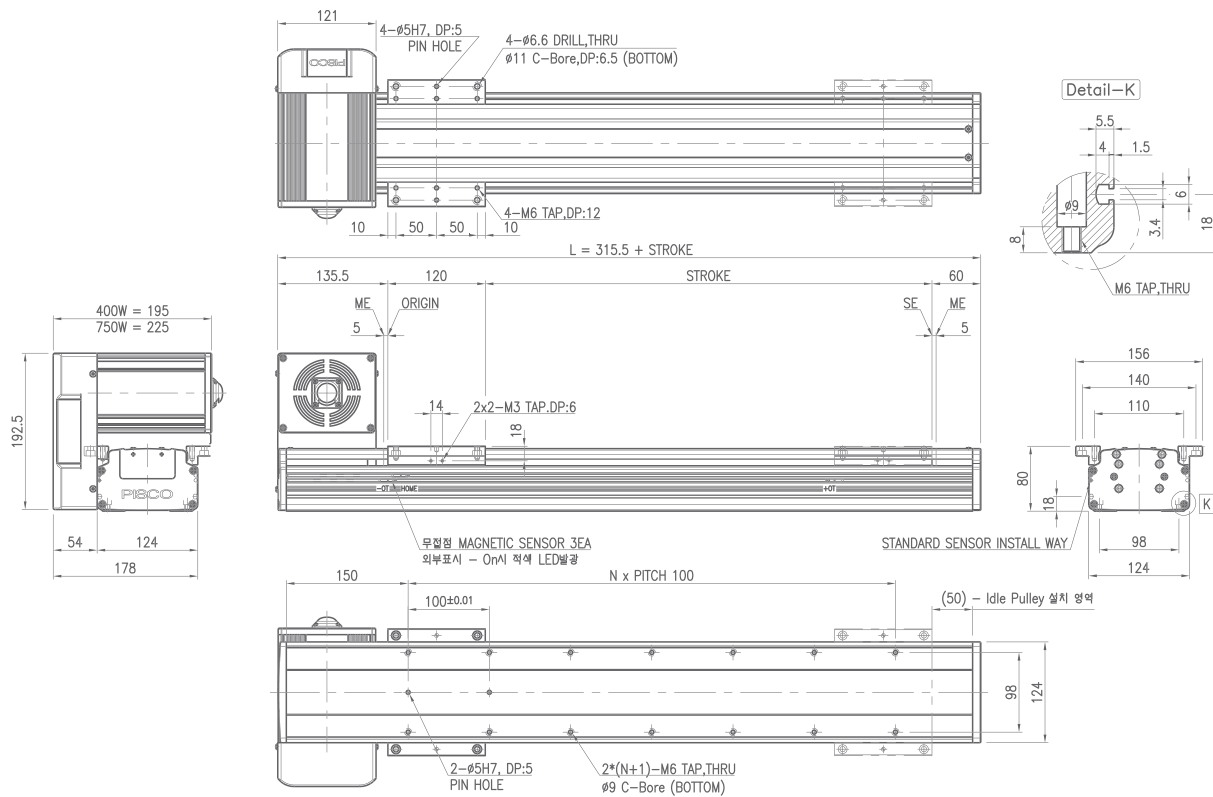

치수도 Dimension (mm)

PHRB120-DR1-40(75)

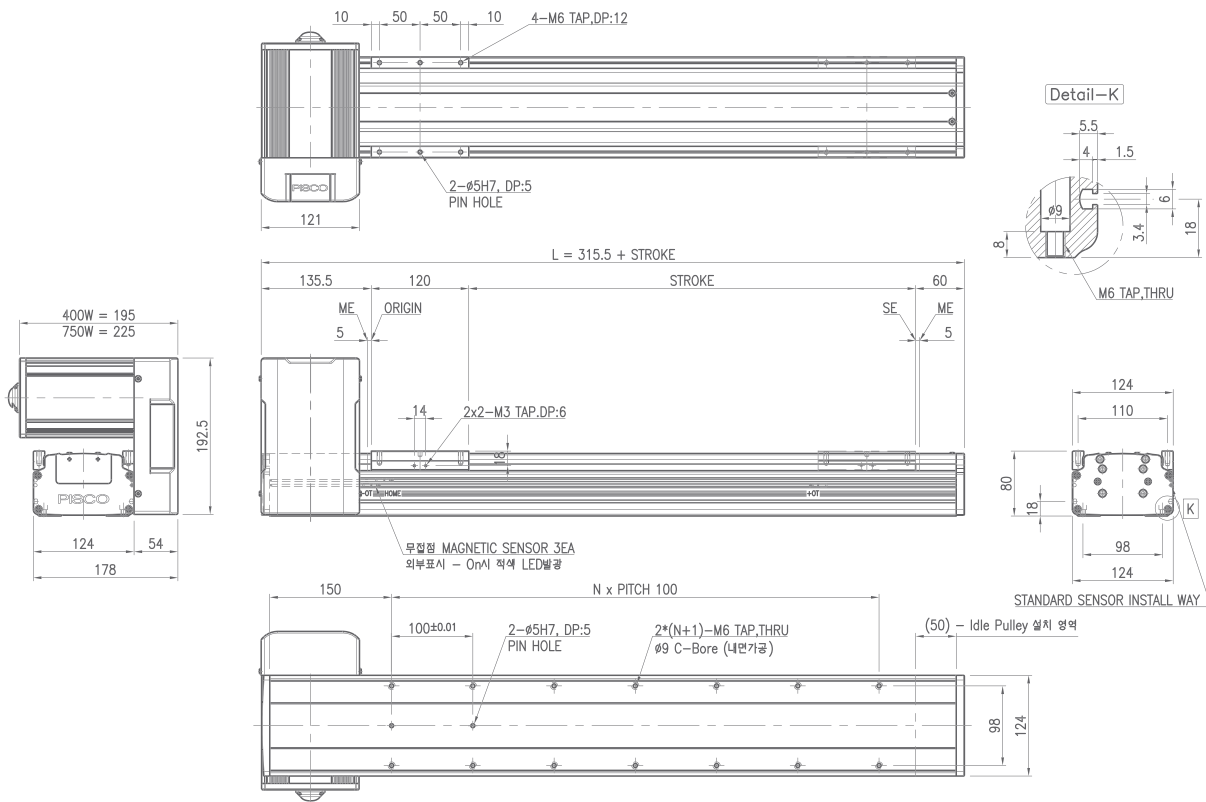

PHRB120-DR2-40(75)

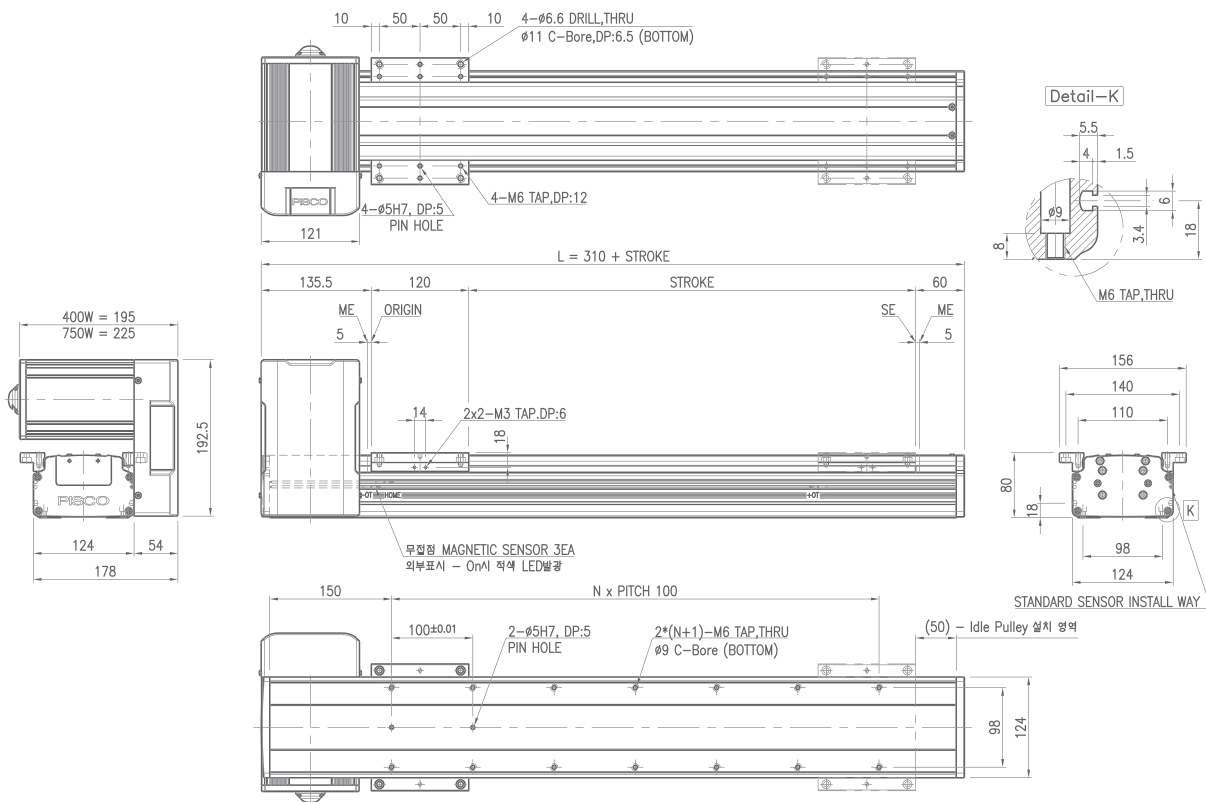

PHRB120-FL1-40(75)

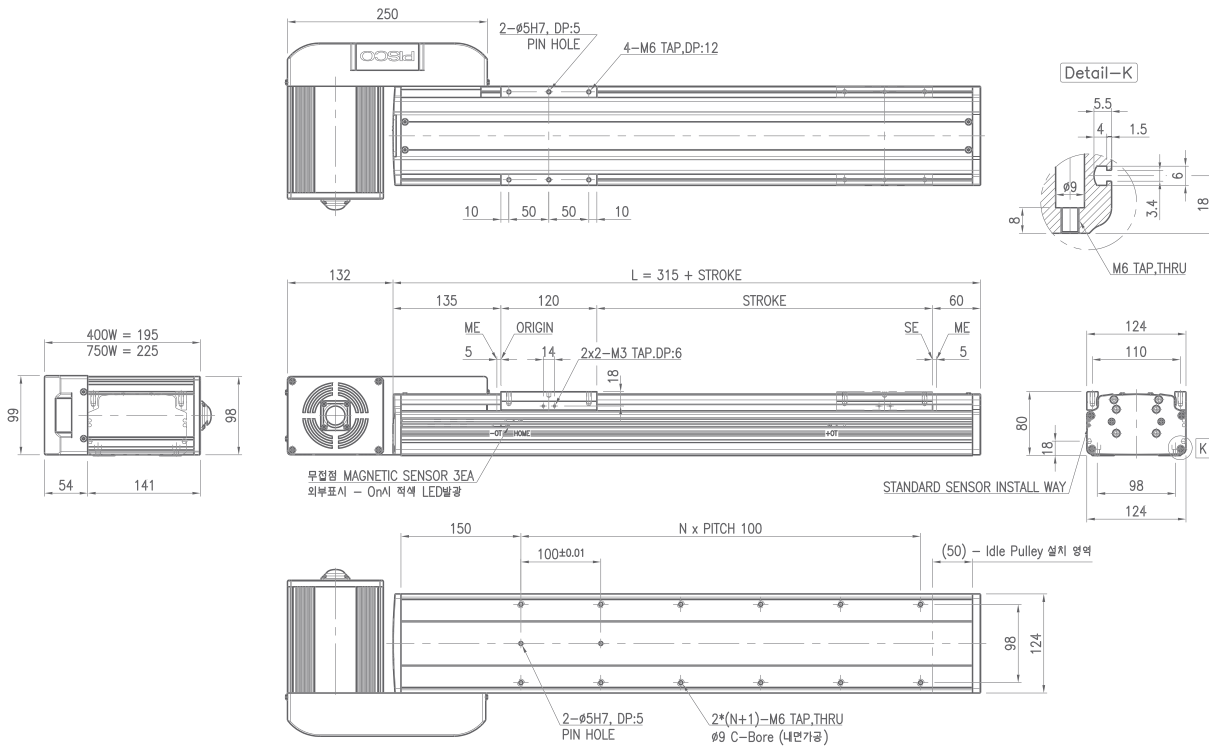

Standard Robot
Timing Belt Type

PHRB

PHRB120-FL2-40(75)

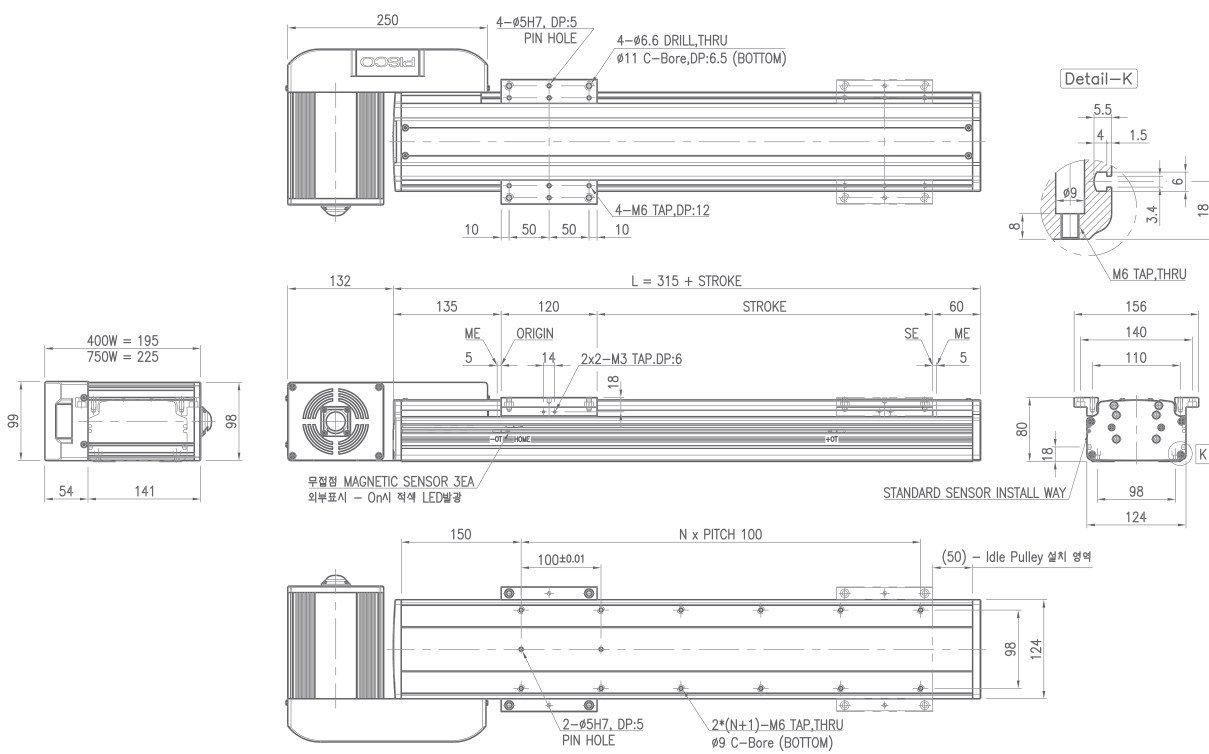

치수도 Dimension (mm)

PHRB120-FR1-40(75)

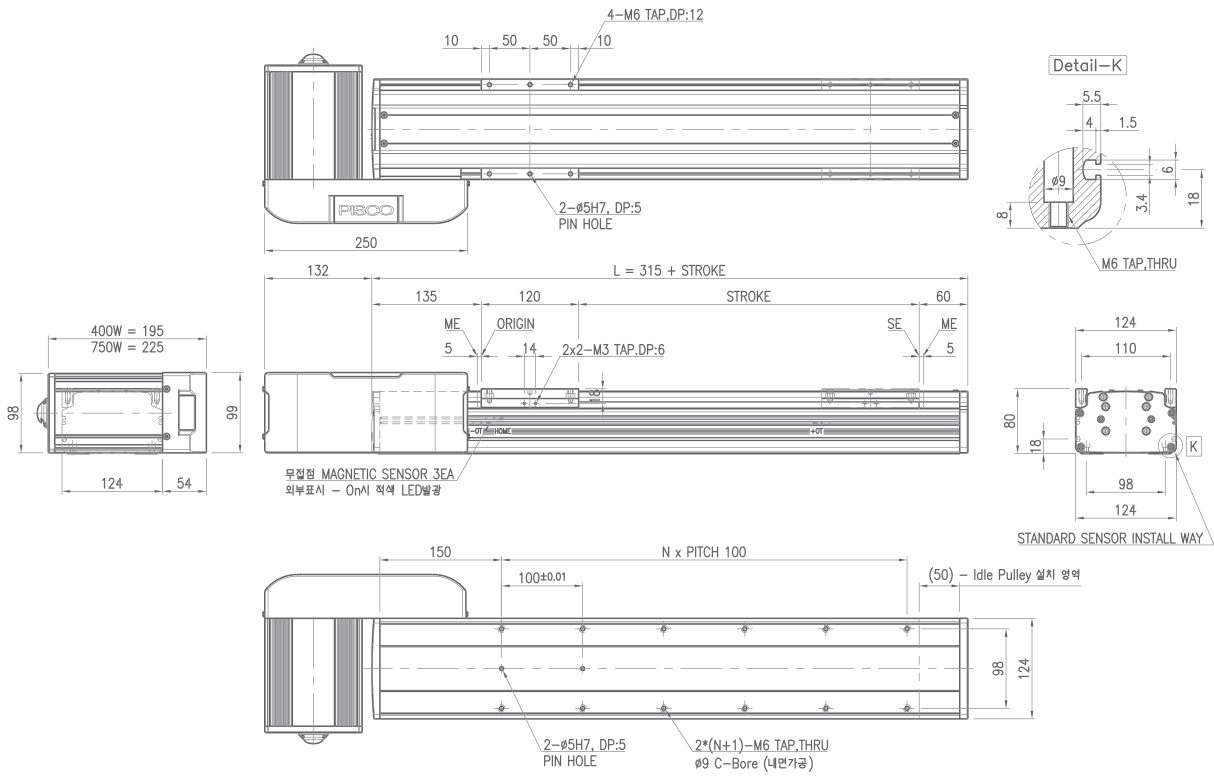

PHRB120-FR2-40(75)

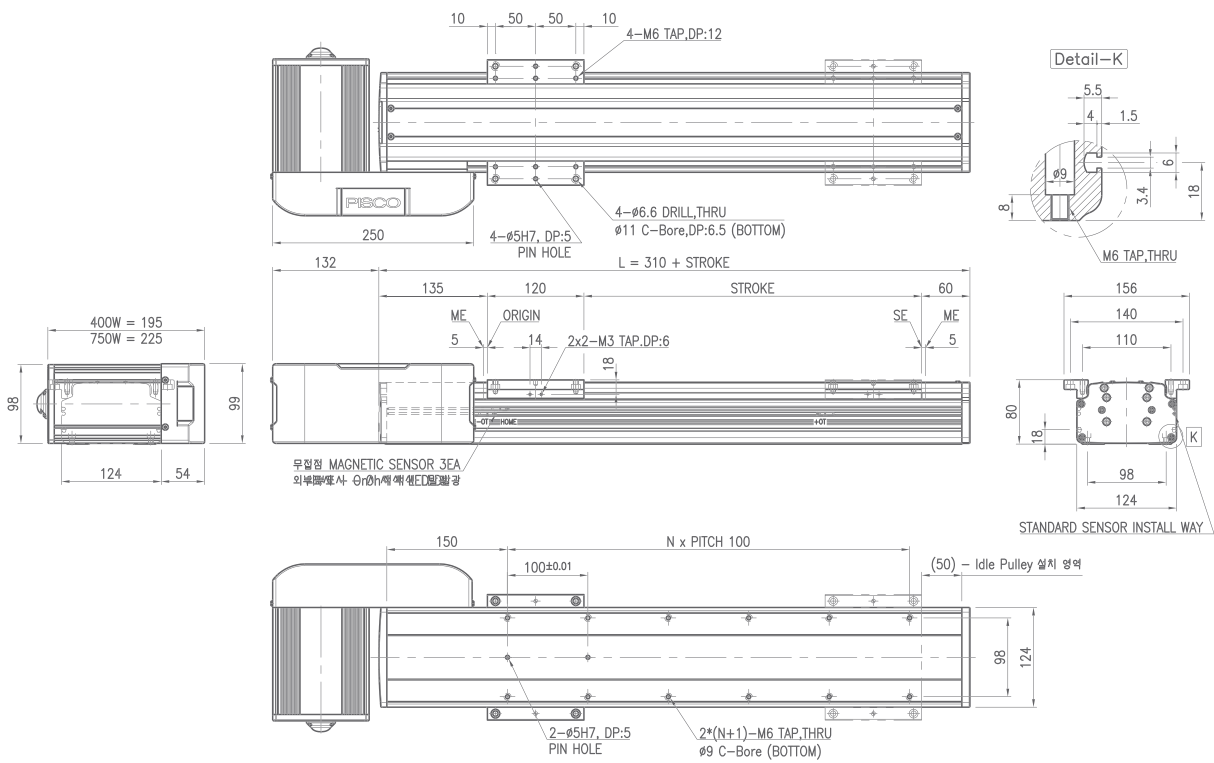

PHRB120-UL1-40(75)

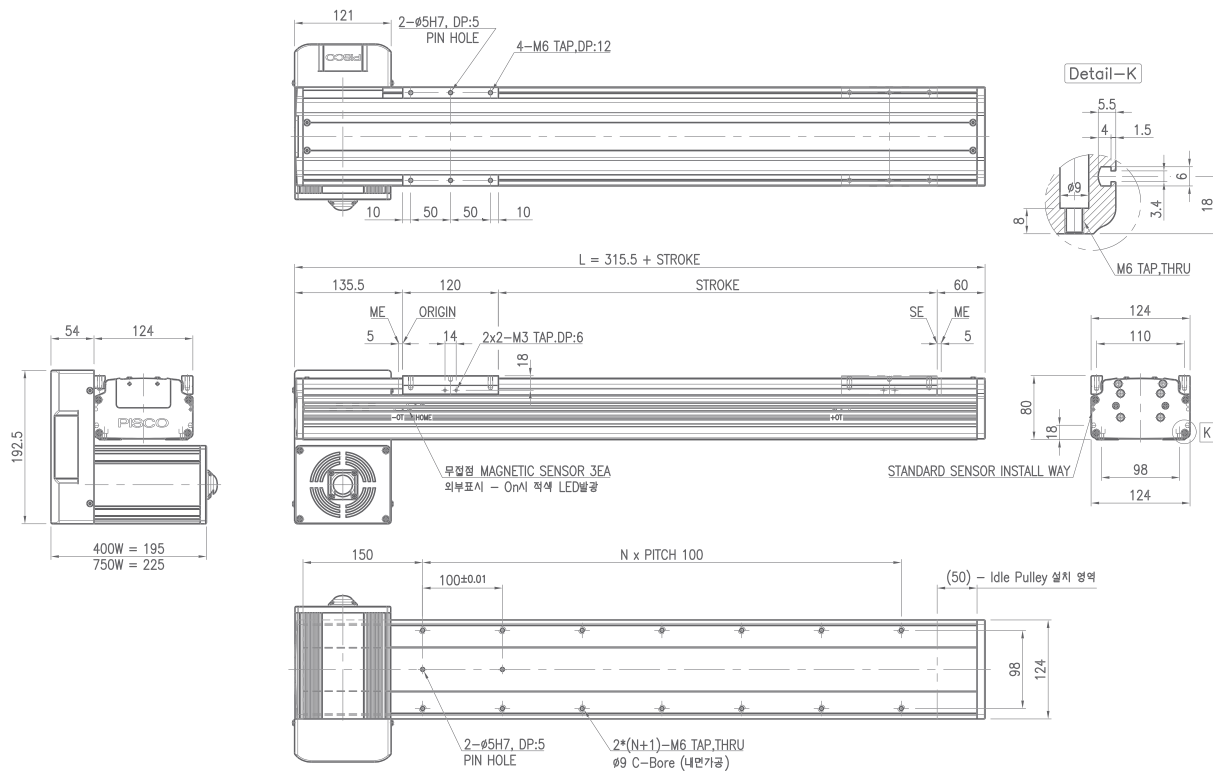

Standard Robot
Timing Belt Type

PHRB

PHRB120-UL2-40(75)

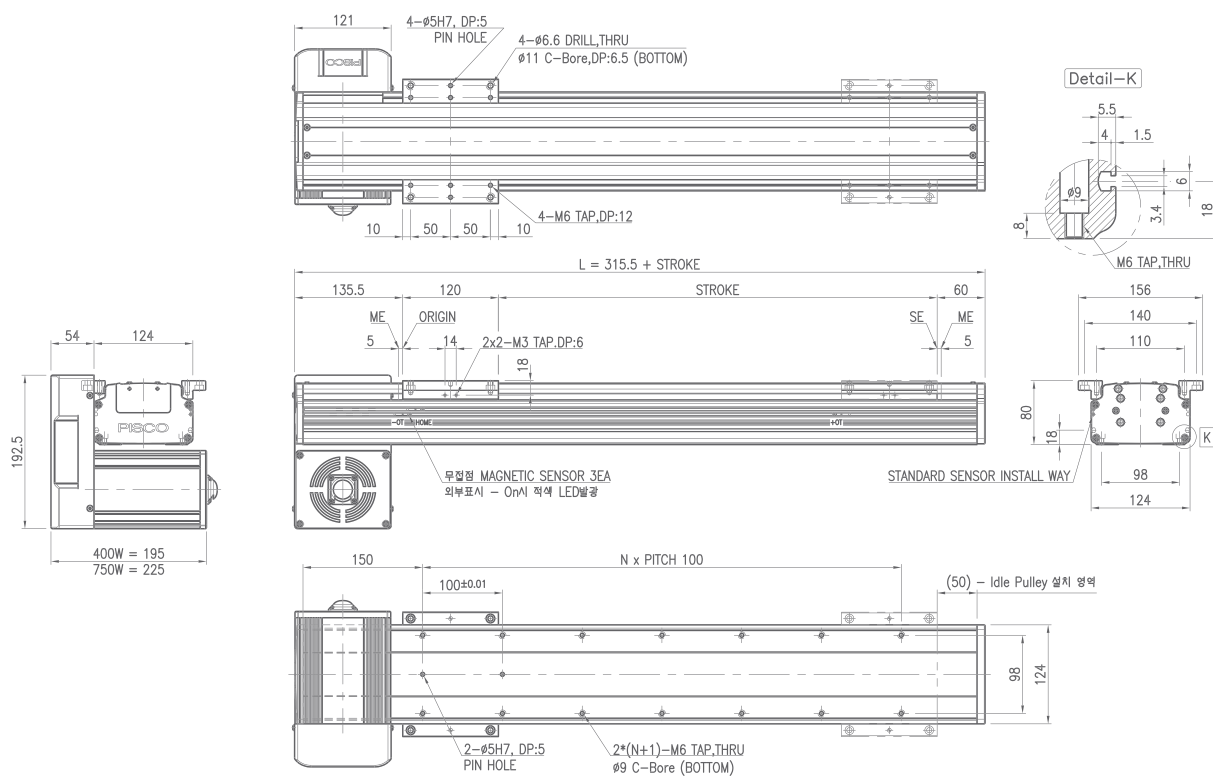

치수도 Dimension (mm)

PHRB120-UR1-40(75)

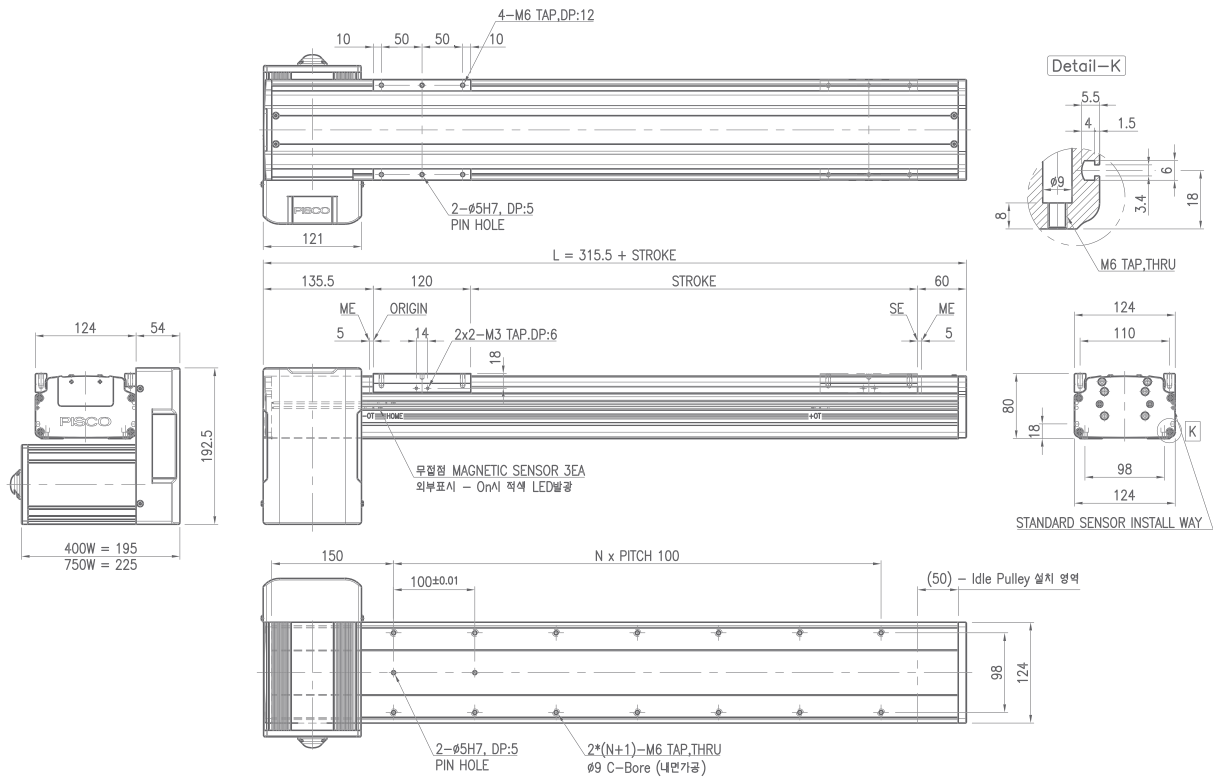

PHRB120-UR2-40(75)

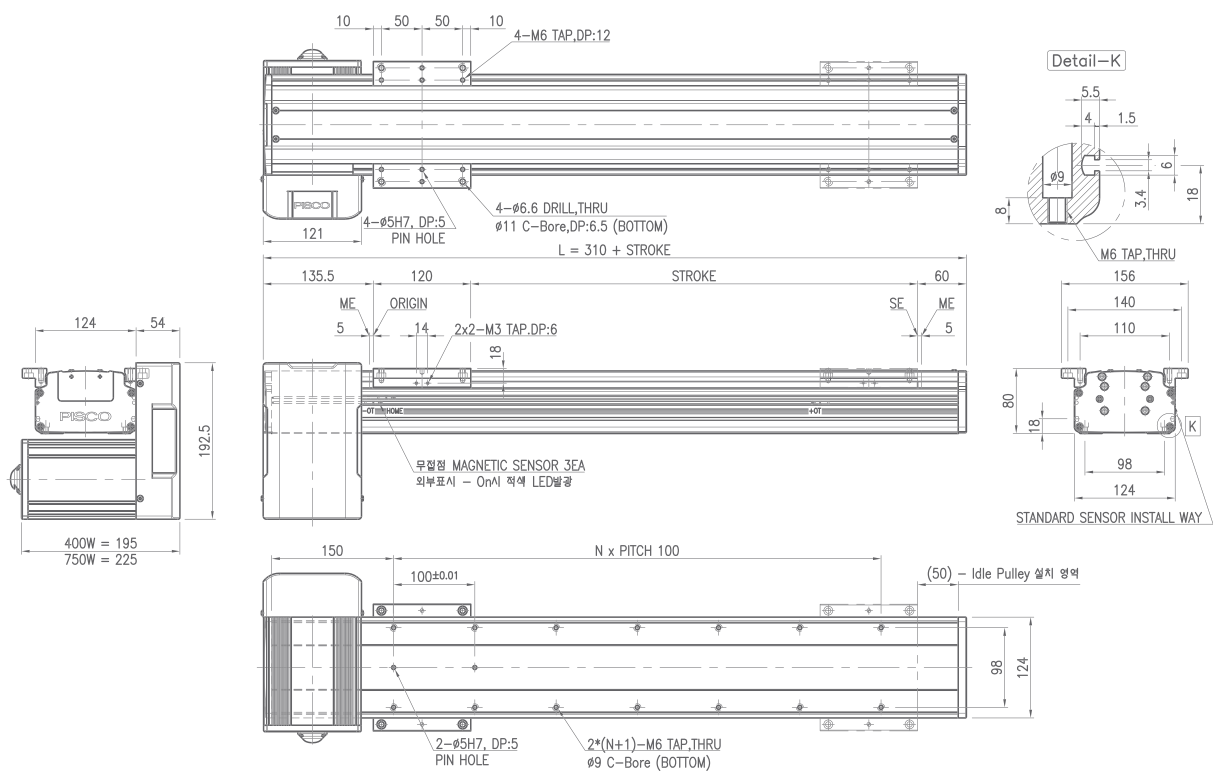

Standard Robot
Timing Belt Type

PHR B

PHRB Series

주문형식 Order Information

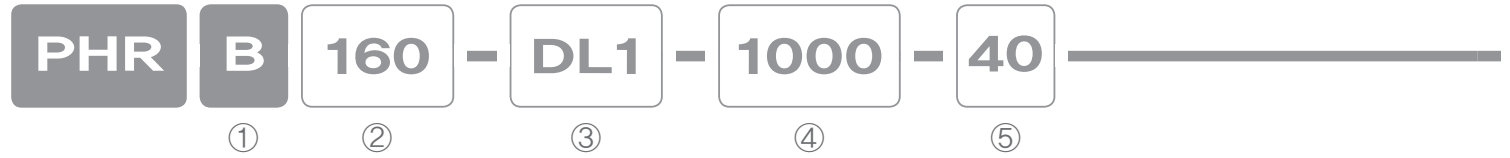

① 형식 Type

B Standard Robot, Belt Type

② 본체 사이즈 Body Size

160 160mm

③ 형상 Shape

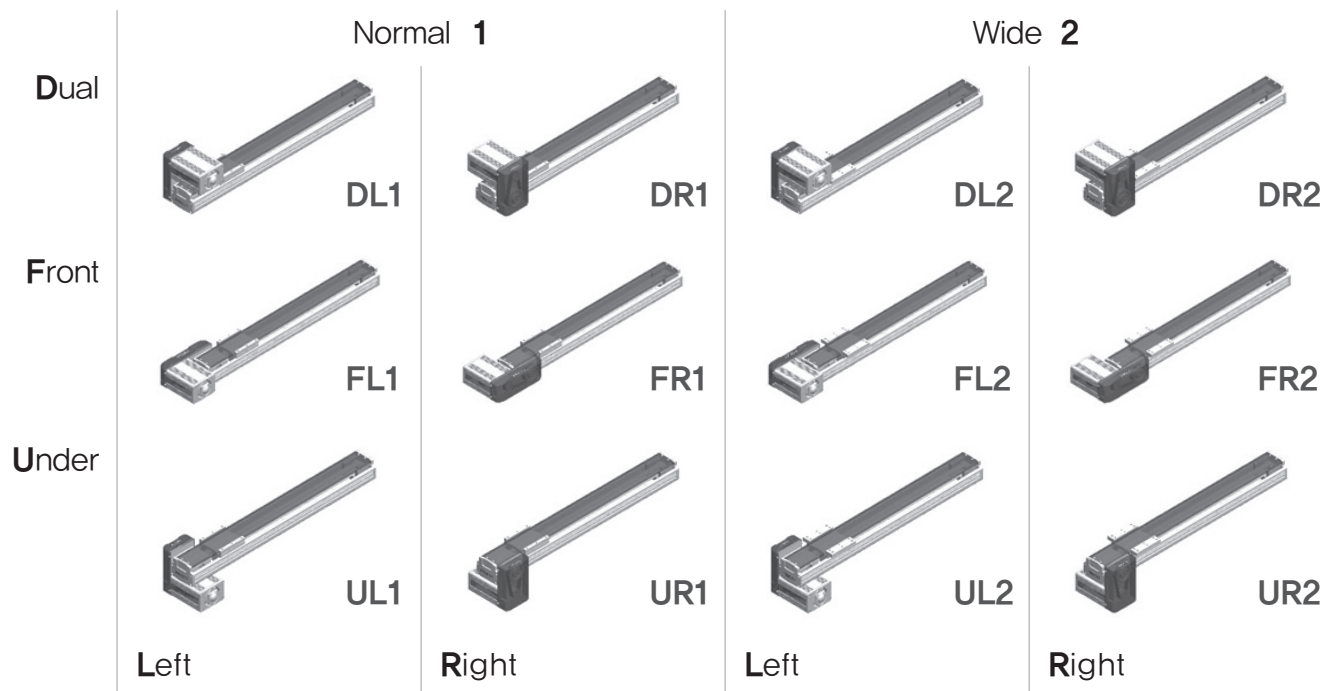

④ 이송거리 Stroke, In increment of 50mm

Max 2500 mm The Distance Between -OT and +OT (mm)

⑤ 모터용량 Motor capacity

40 400W **75** 750W

선택사양 Option



⑥ 로봇 색상 Robot Color Option

None	White (Standard)	B	Black Anodizing
-------------	------------------	----------	-----------------

⑦ 센서 Sensor

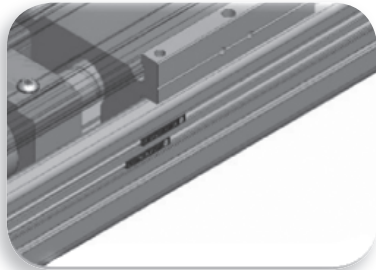

None	External DC-24V Proximity LED Sensor (Standard)
-------------	---

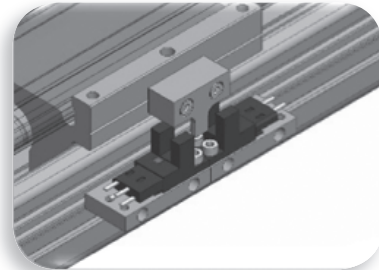

E1	SUNX (PM-Y54)
E2	OMRON (EE-SX674A)
E3	SUNX (PM-L24)

⑧ 표면처리 Surface Treatment

None	Without Surface Treatment
R1	LM Rail-Raydent
R2	LM Rail+Block-Raydent

⑨ 감속기 Reduction Gear

None	Tming Pulley Reduction
G**	With Reduction Gear
**	Reduction Gear Ratio 03~10

⑩ 케이블베어 Cableveyor

None	Without Cableveyor	C	With Cableveyor
-------------	--------------------	----------	-----------------

Standard Robot
Timing Belt Type

PHRB

사양 Specifications

공통사양 Common Specifications

Stroke Range	mm	100 ~ 2500
Positioning Repeatability		±0.1
Drive System	mm	Timing Belt
Guide		2 Way 20W – 2UU
Main Base & Slide		Aluminum Profile, Soft White Anodizing
Cover		Aluminum Profile, Soft White Anodizing
Sensor Cable Length	mm	Standard Sensor Cable Body Out 300
Driving Pulley		P.C.D Ø33.42

※ Cover에 Transparent PC Extrude Profile의 사양은 특주로 대응됩니다.

허용 이격 거리 Allowable Overhang Distance

Installation Types Load capacity		Setting Angle	Allowable Overhang Distance (mm)			
			40kg	50kg	60kg	70kg
Horizontal Use		0°	335	270	230	200
		45°	275	222	187	162
		90°	800	800	670	560
Estimated Condition	Stroke : 1000mm Speed : 1000mm/sec Acceleration : 0.2sec Life in traveled distance : 15000km or 15000Hr					

최고속도 및 부하하중 Max Speed & Pay Load

Reduction Gear Ratio	Max Speed mm/s	Horizontal Moving AC Servo Motor Output		Remark
		400W	750W	
G06	875	70kg	70kg	
G05	1050	46kg	70kg	
G04	1313	27kg	70kg	
G03	1750	12kg	61kg	
None (1/2.5)	2100	4kg	38kg	
Estimated Condition	Stroke : 1000mm Speed : Max Speed Acceleration : 0.3sec Servo Motor Rotate : 3000rpm			

이송거리별 무게 Weight by Stroke

Motor Capacity	Stroke (mm) & Weight (kg)																								
	100	200	300	400	500	600	700	800	900	1000	1100	1200	1300	1400	1500	1600	1700	1800	1900	2000	2100	2200	2300	2400	2500
400W	18.5	19.8	21.1	22.4	23.7	25.0	26.3	27.6	28.9	30.2	31.6	32.9	34.2	35.5	36.8	38.1	39.4	40.7	42.0	43.3	44.7	46.0	47.3	48.6	49.9
750W	19.9	21.2	22.5	23.8	25.1	26.4	27.8	29.1	30.4	31.7	33.0	34.3	35.6	36.9	38.2	39.6	40.9	42.2	43.5	44.8	46.1	47.4	48.7	50.1	51.4

PHRB160-DL1-40(75)

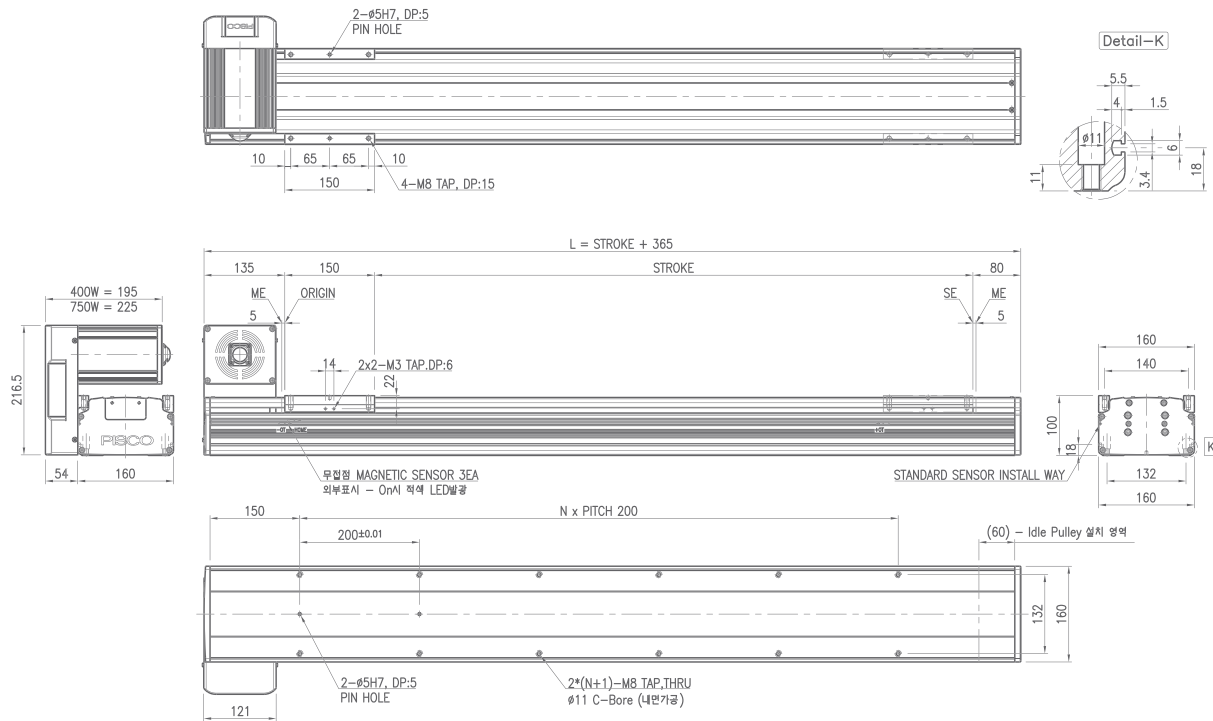

Standard Robot
Timing Belt Type

PHRB

PHRB160-DL2-40(75)

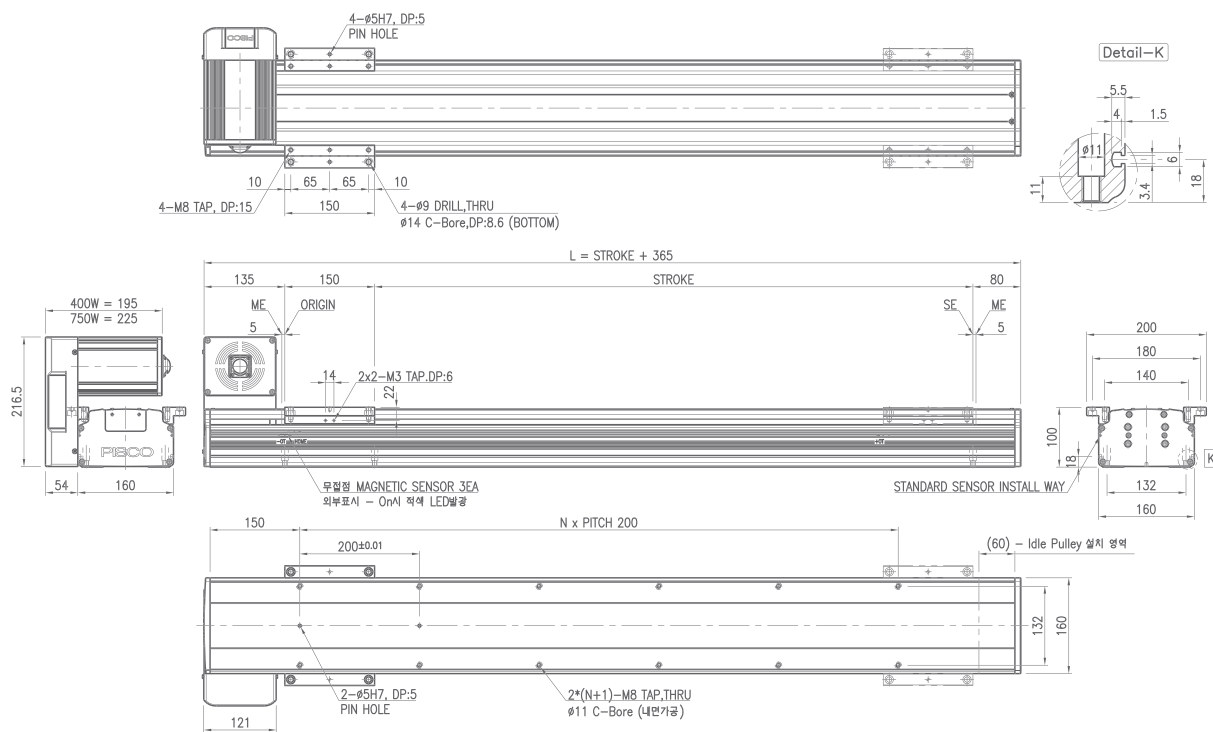

치수도 Dimension (mm)

PHRB160-DR1-40(75)

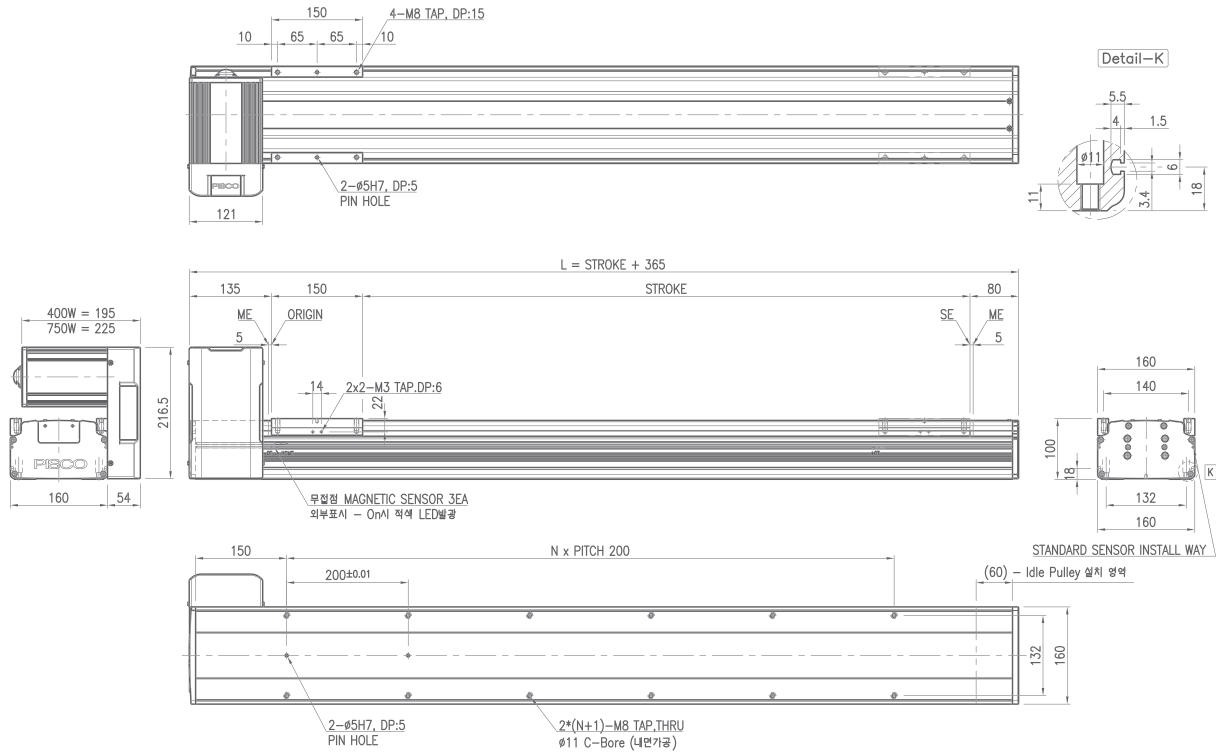

PHRB160-DR2-40(75)

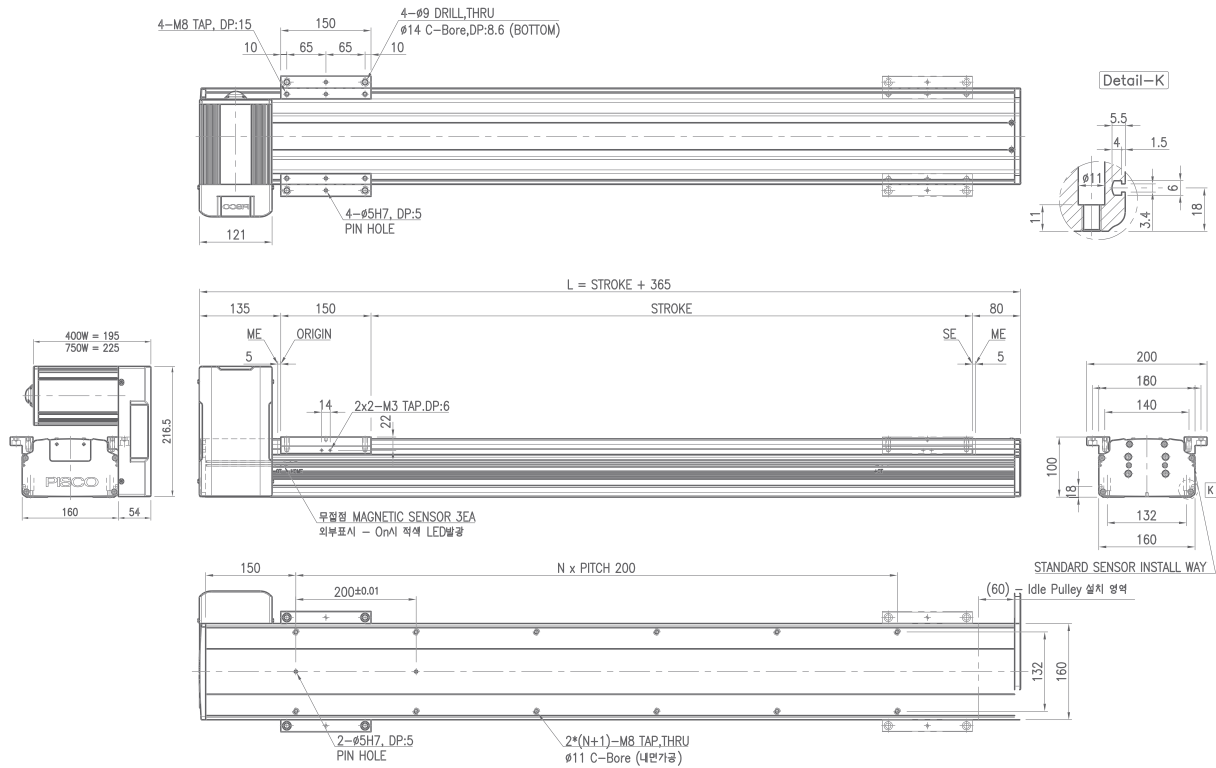

PHRB160-FL1-40(75)

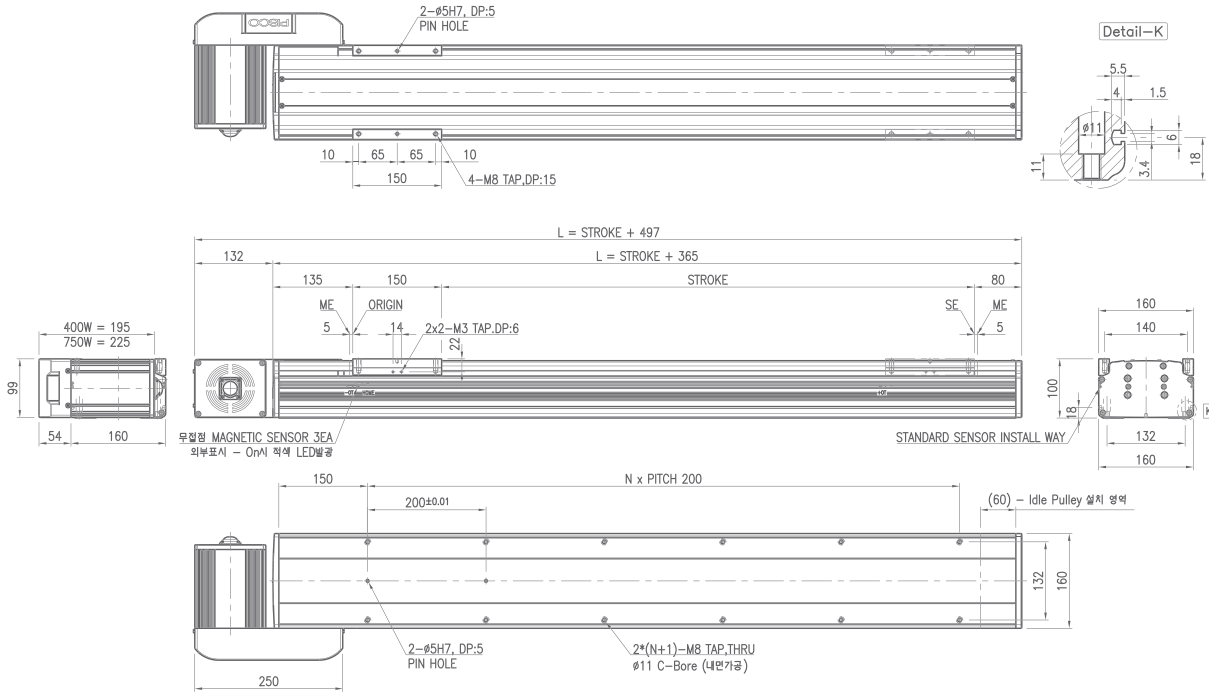

Standard Robot
Timing Belt Type

PHRB

PHRB160-FL2-40(75)

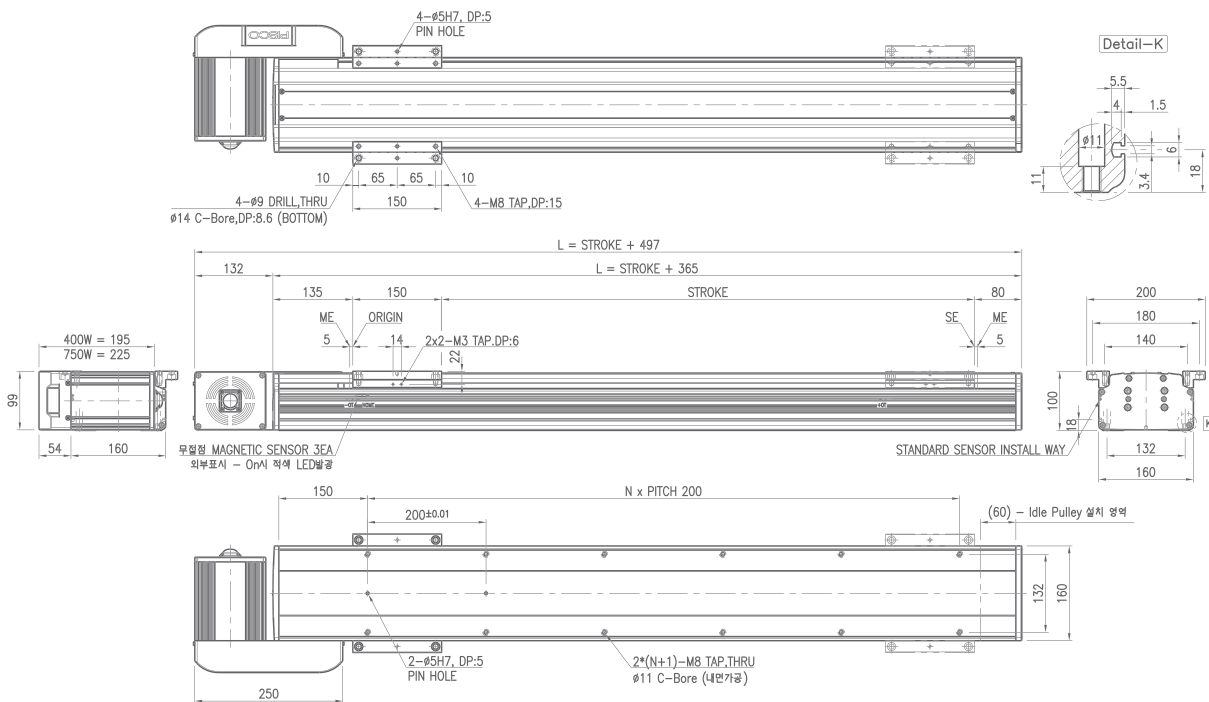

치수도 Dimension (mm)

PHRB160-FR1-40(75)

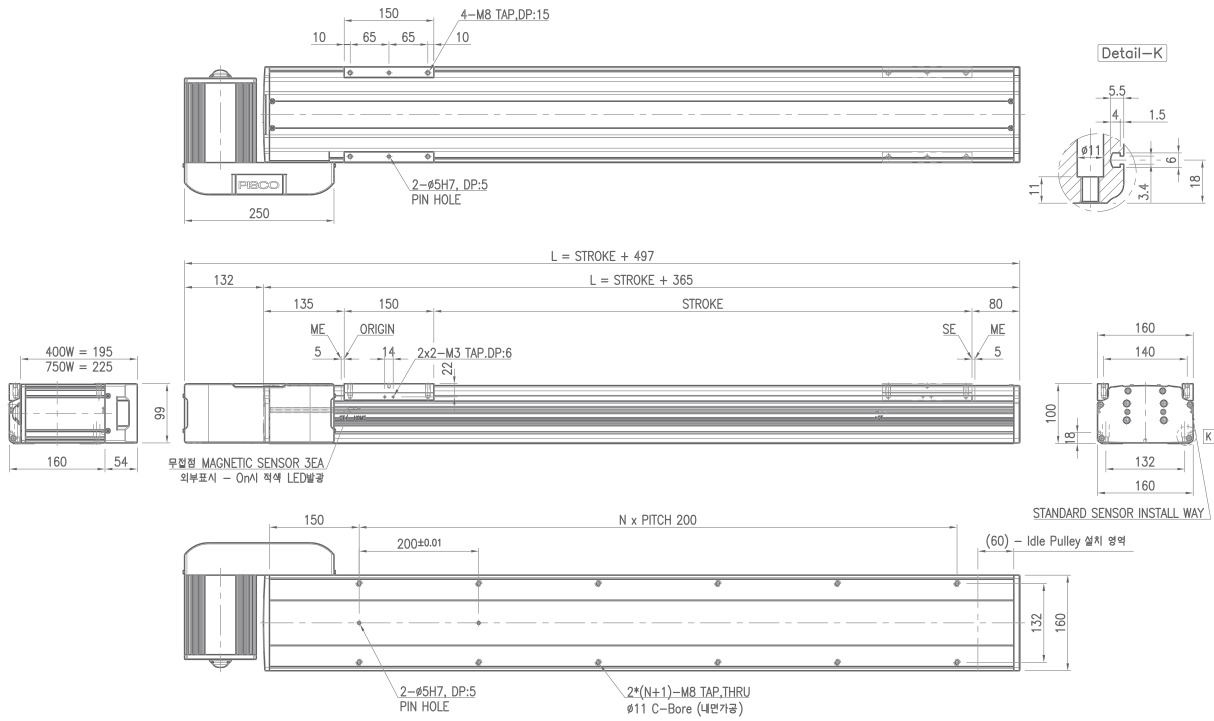

PHRB160-FR2-40(75)

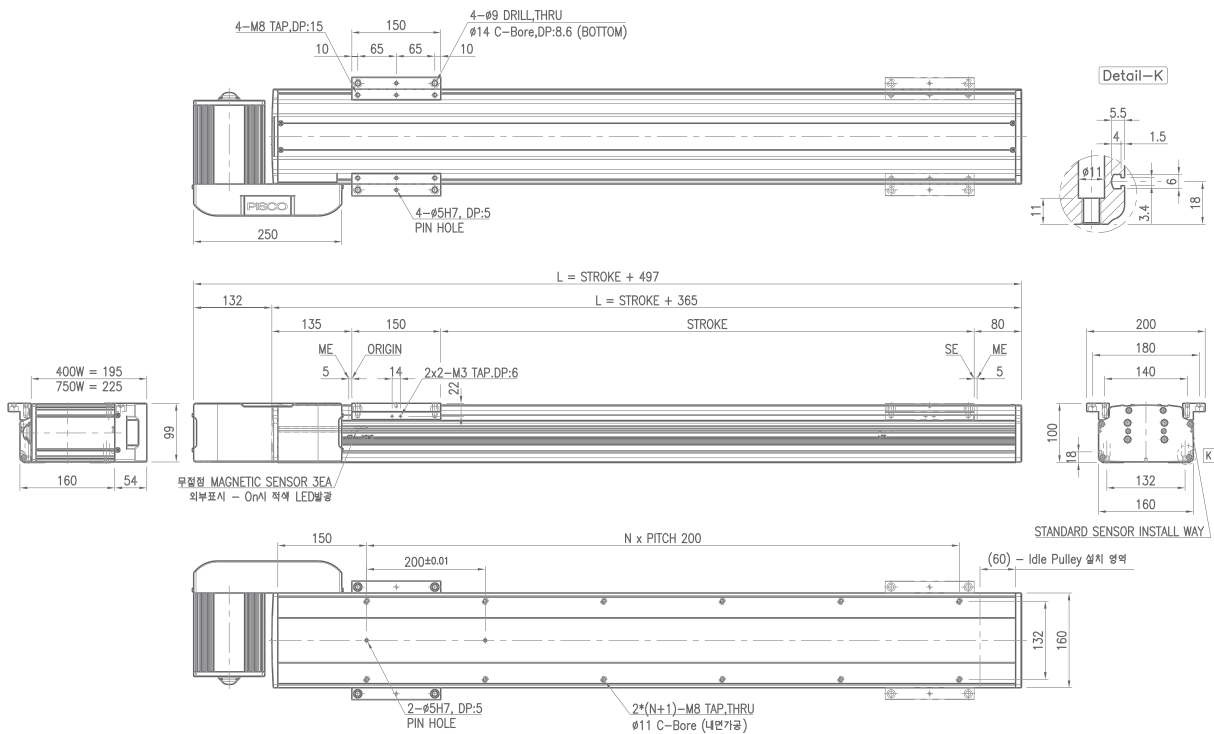

PHRB160-UL1-40(75)

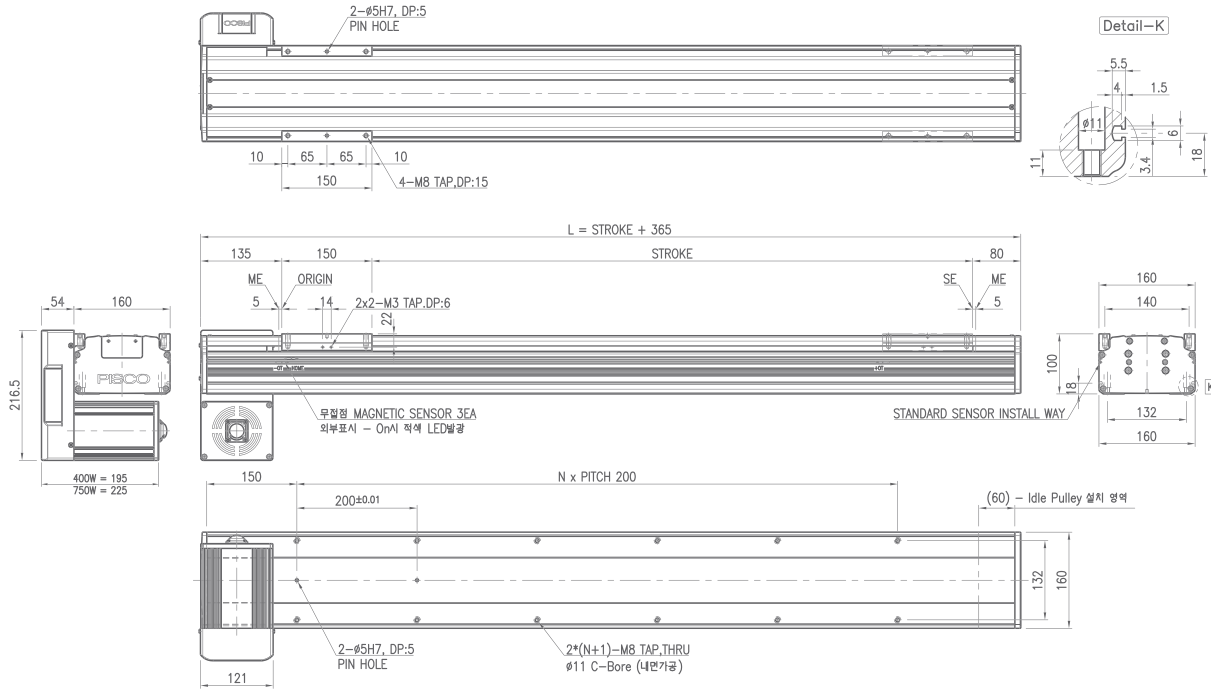

Standard Robot
Timing Belt Type

PHRB

PHRB160-UL2-40(75)

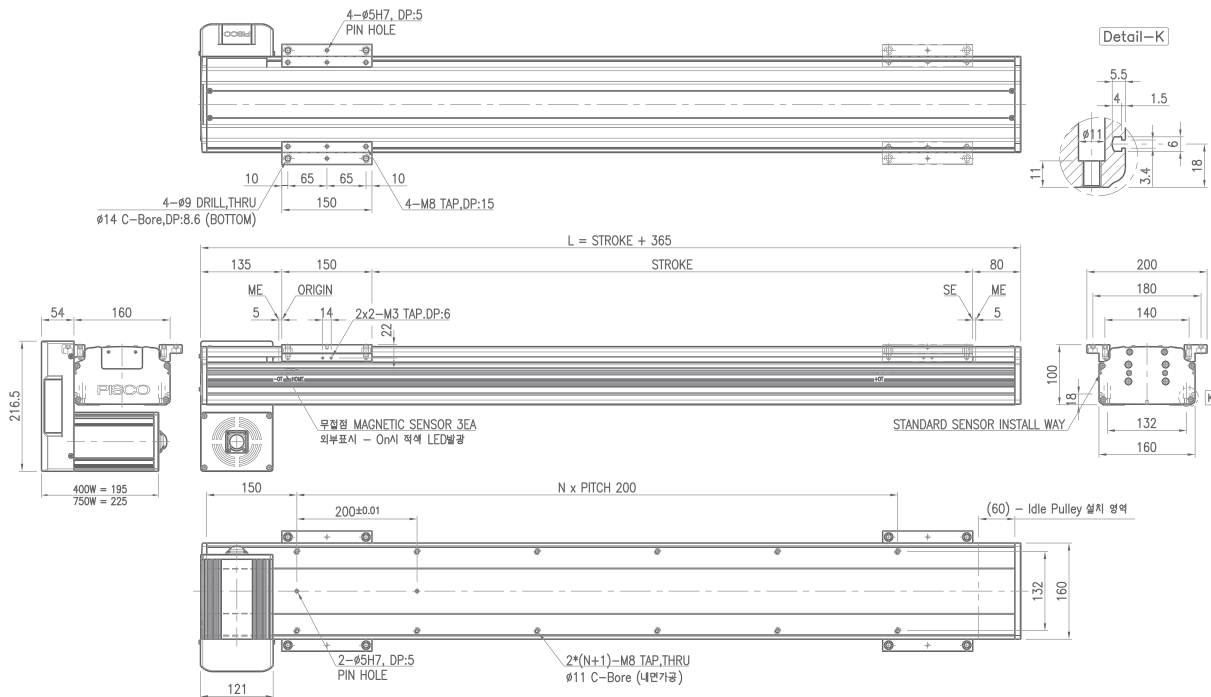

치수도 Dimension (mm)

PHRB160-UR1-40(75)

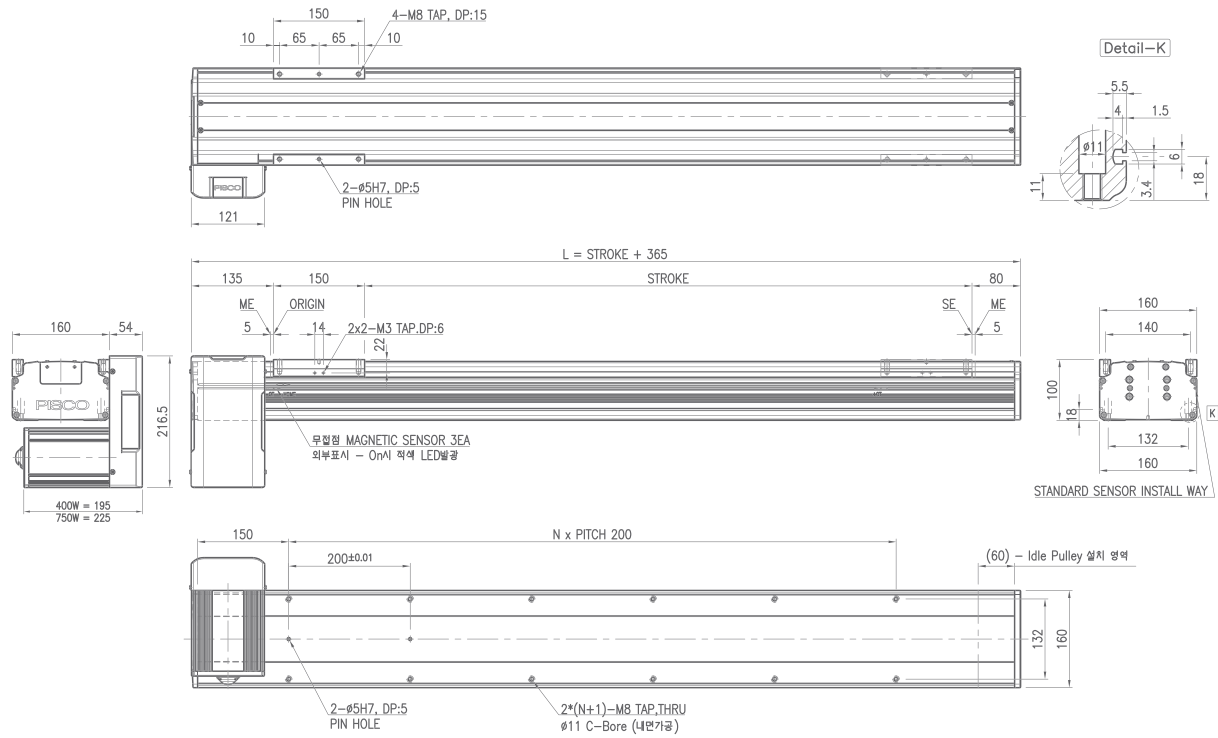

PHRB160-UR2-40(75)

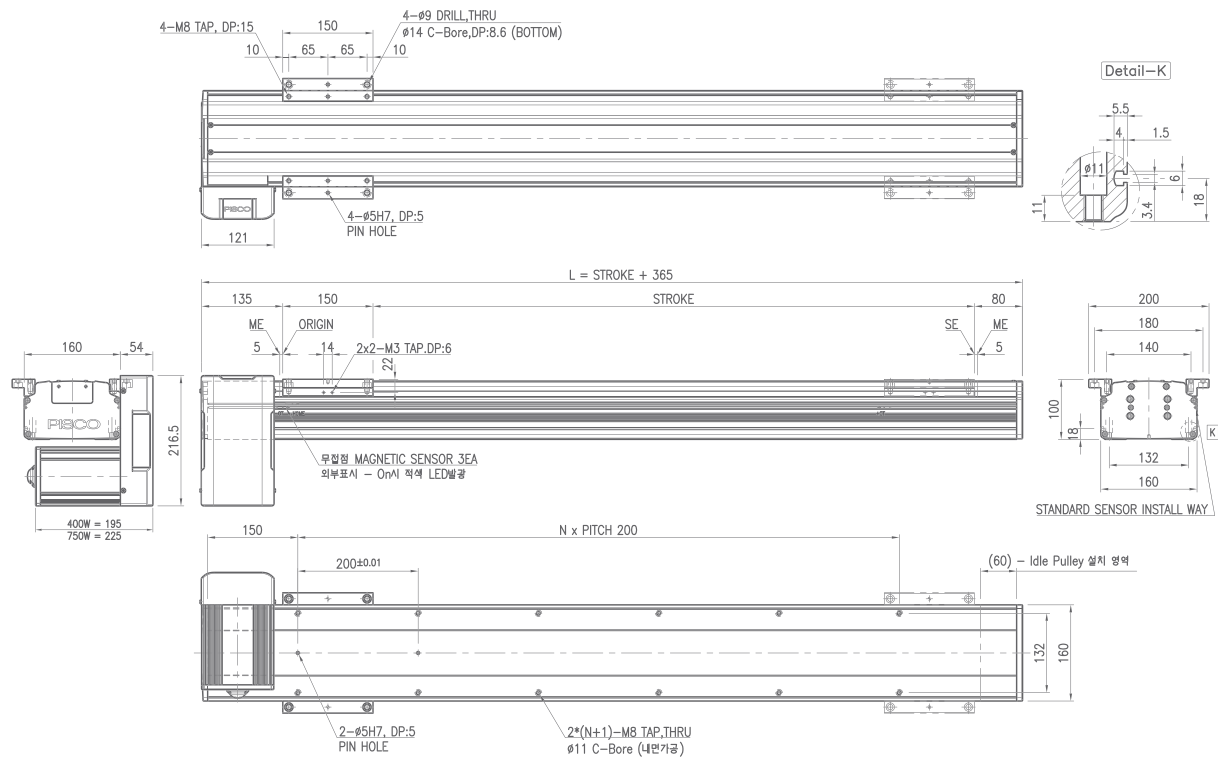

Standard Robot
Timing Belt Type

PHR B

PHRB Series

주문형식 Order Information



① 형식 Type

B Standard Robot, Belt Type

② 본체 사이즈 Body Size

200 200mm

③ 형상 Shape

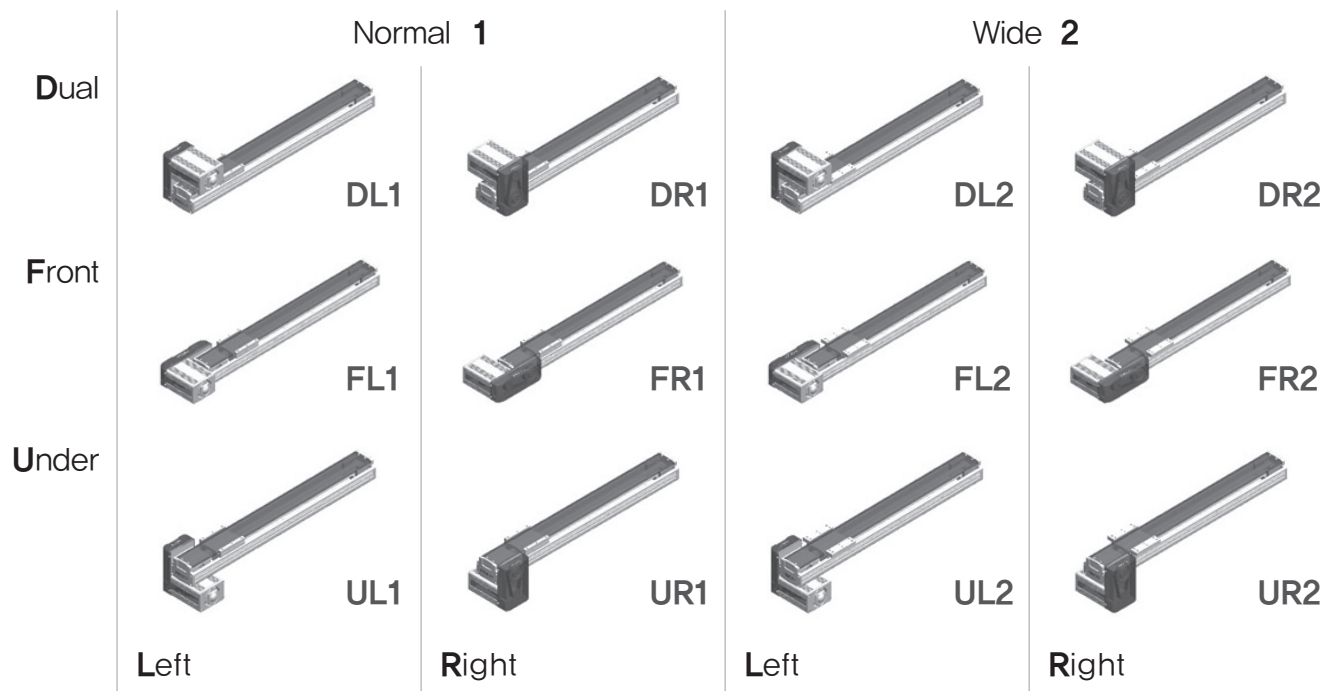

④ 이송거리 Stroke, In increment of 50mm

Max 3000 mm The Distance Between -OT and +OT (mm)

⑤ 모터용량 Motor capacity

40 400W **75** 750W

선택사양 Option



⑥ 로봇 색상 Robot Color Option

None	White (Standard)	B	Black Anodizing
-------------	------------------	----------	-----------------

⑦ 센서 Sensor

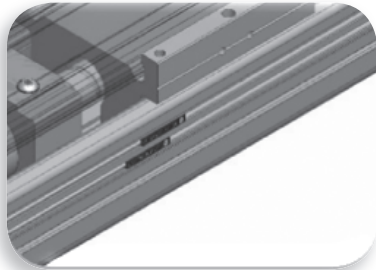

None	External DC-24V Proximity LED Sensor (Standard)
-------------	---

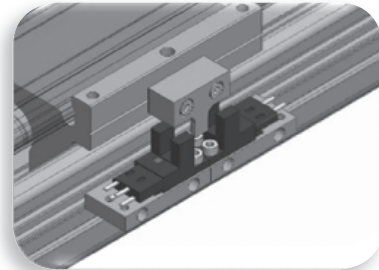

E1	SUNX (PM-Y54)
E2	OMRON (EE-SX674A)
E3	SUNX (PM-L24)

⑧ 표면처리 Surface Treatment

None	Without Surface Treatment
R1	LM Rail-Raydent
R2	LM Rail+Block-Raydent

⑨ 감속기 Reduction Gear

None	Tming Pulley Reduction
G**	With Reduction Gear
**	Reduction Gear Ratio 03~10

⑩ 케이블베어 Cableveyor

None	Without Cableveyor	C	With Cableveyor
-------------	--------------------	----------	-----------------

Standard Robot
Timing Belt Type

PHRB

사양 Specifications

공통사양 Common Specifications

Stroke Range	mm	100 ~ 3000
Positioning Repeatability		±0.1
Drive System	mm	Timing Belt
Guide		2 Way 25W – 2UU
Main Base & Slide		Aluminum Profile, Soft White Anodizing
Cover		Aluminum Profile, Soft White Anodizing
Sensor Cable Length	mm	Standard Sensor Cable Body Out 300
Driving Pulley		P.C.D Ø42.97

※ Cover에 Transparent PC Extrude Profile의 사양은 특주로 대응됩니다.

허용 이격 거리 Allowable Overhang Distance

Installation Types Load capacity		Setting Angle	Allowable Overhang Distance (mm)			
			60kg	80kg	100kg	120kg
Horizontal Use		0°	450	350	280	240
		45°	353	268	219	183
		90°	800	800	630	500
Estimated Condition	Stroke : 1000mm Speed : 1000mm/sec Acceleration : 0.2sec Life in traveled distance : 15000km or 15000Hr					

최고속도 및 부하하중 Max Speed & Pay Load

Reduction Gear Ratio	Max Speed mm/s	Horizontal Moving AC Servo Motor Output		Remark
		400W	750W	
G07	964	55kg	120kg	
G06	1125	40kg	120kg	
G05	1350	25kg	105kg	
G04	1688	12kg	63kg	
None (1/3)	2250	3kg	27kg	
Estimated Condition	Stroke : 1000mm Speed : Max Speed Acceleration : 0.3sec Servo Motor Rotate : 3000rpm			

이송거리별 무게 Weight by Stroke

Motor Capacity	Stroke (mm) & Weight (kg)																								
	100	200	300	400	500	600	700	800	900	1000	1100	1200	1300	1400	1500	1600	1700	1800	1900	2000	2100	2200	2300	2400	2500
400W	27.1	29.5	31.8	34.1	36.5	38.8	41.1	43.4	45.8	48.1	50.4	52.7	55.1	57.4	59.7	62.1	64.4	66.7	69.0	71.4	73.7	76.0	78.4	80.7	83.0
750W	28.6	31.0	33.3	35.6	38.0	40.3	42.6	44.9	47.3	49.6	51.9	54.3	56.6	58.9	61.2	63.6	65.9	68.2	70.5	72.9	75.2	77.5	79.9	82.2	84.5

PHRB200-DL1-40(75)

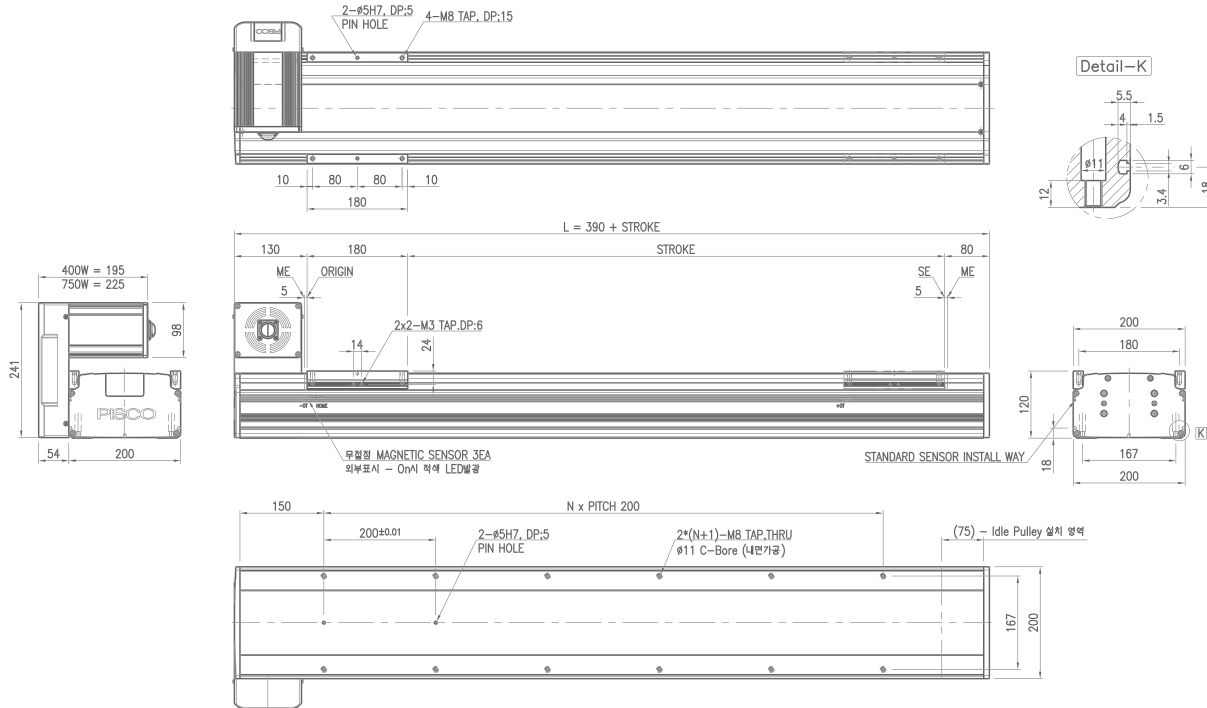

Standard Robot
Timing Belt Type

PHRB

PHRB200-DL2-40(75)

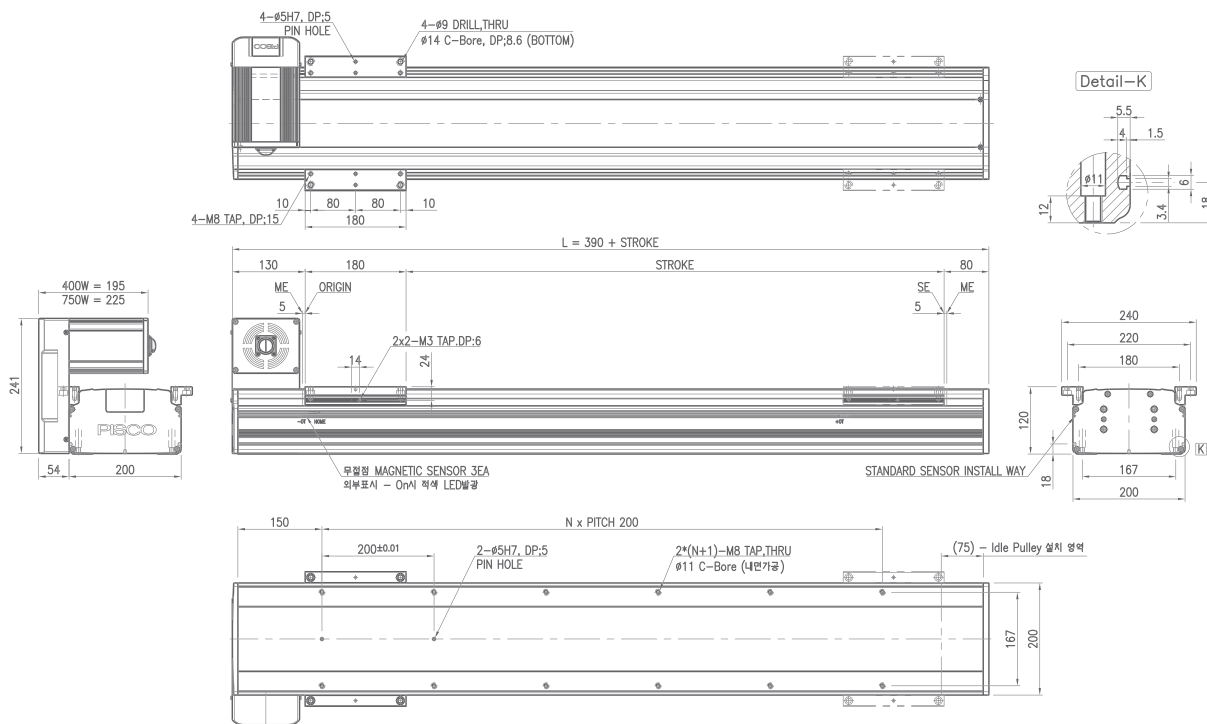

치수도 Dimension (mm)

PHRB200-DR1-40(75)

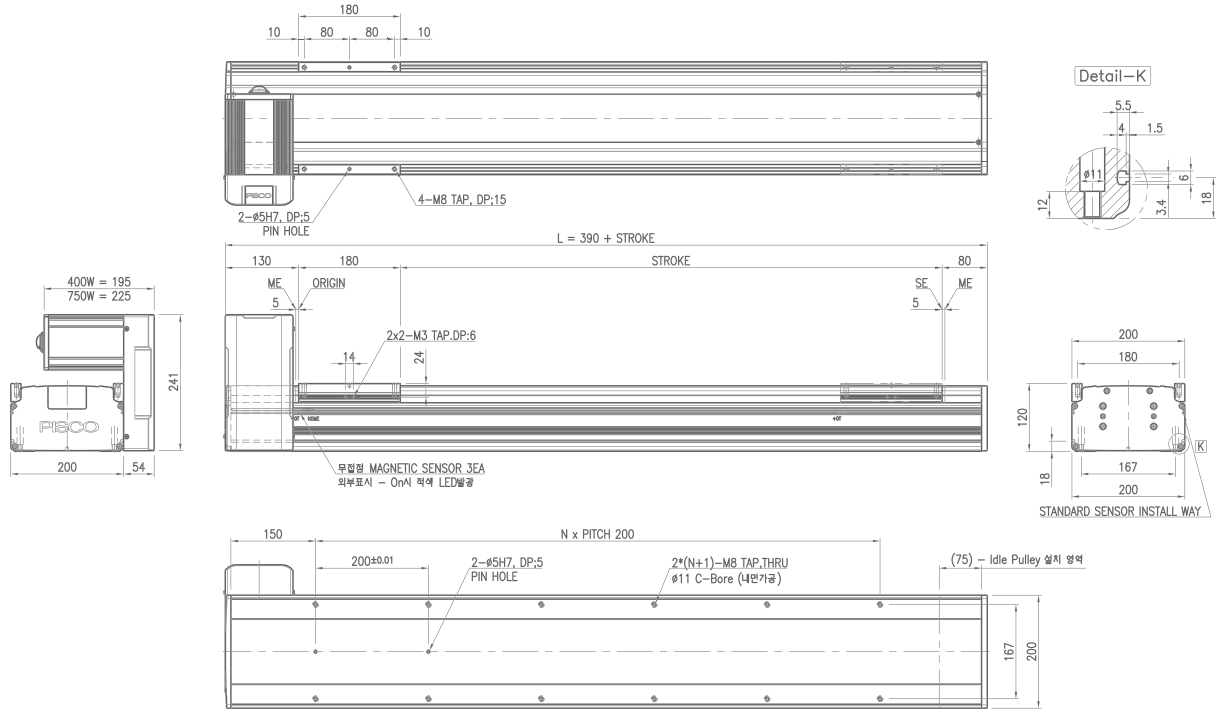

PHRB200-DR2-40(75)

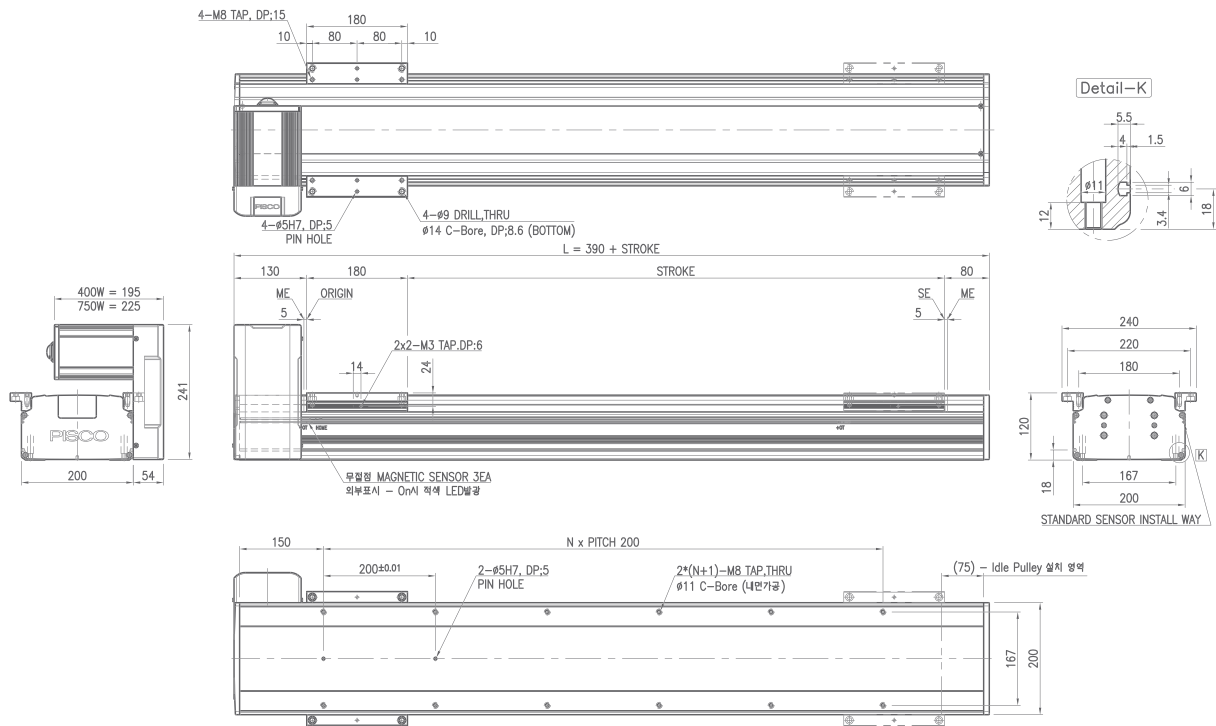

치수도 Dimension (mm)

PHRB200-FR1-40(75)

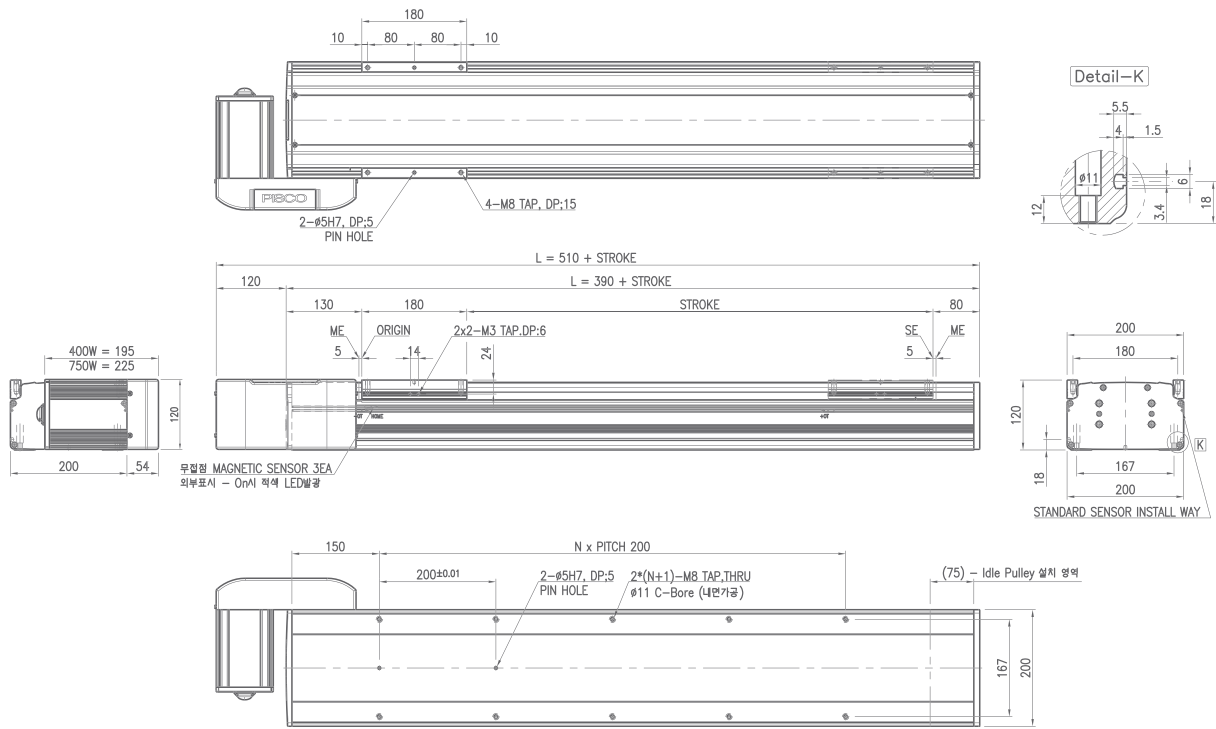

PHRB200-FR2-40(75)

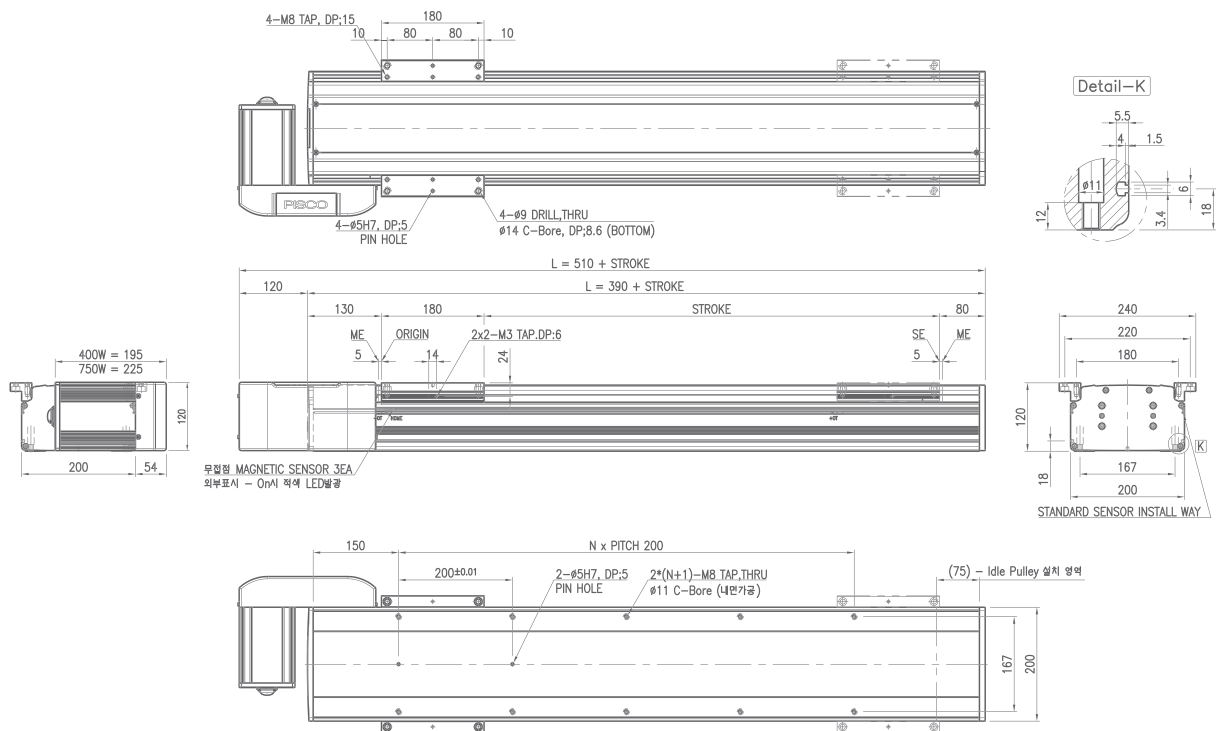

PHRB200-UL1-40(75)

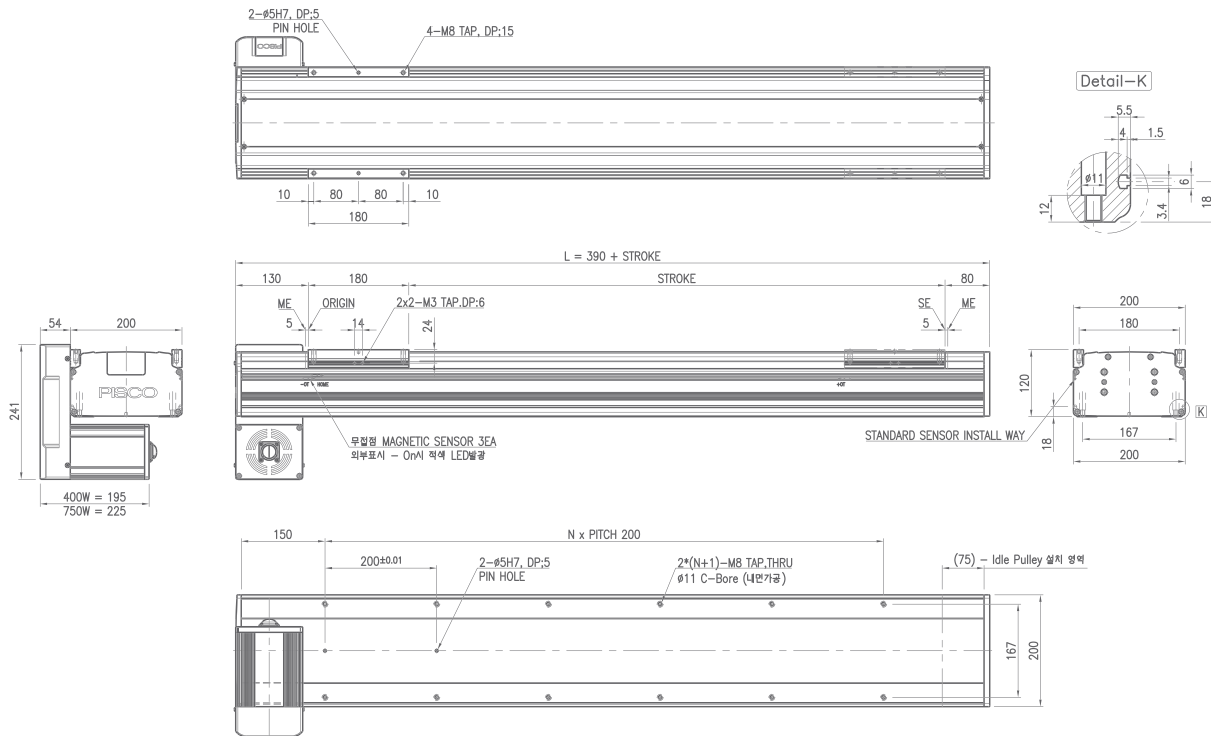

Standard Robot
Timing Belt Type

PHRB

PHRB200-UL2-40(75)

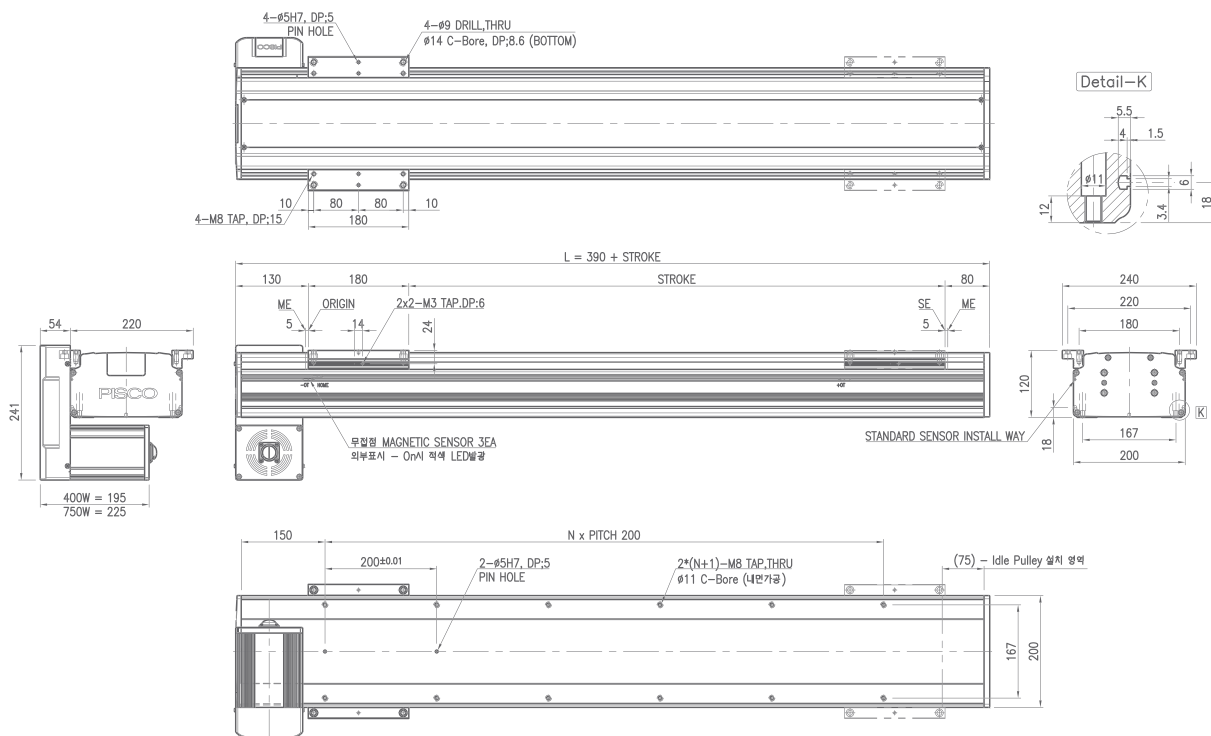

치수도 Dimension (mm)

PHRB200-UR1-40(75)

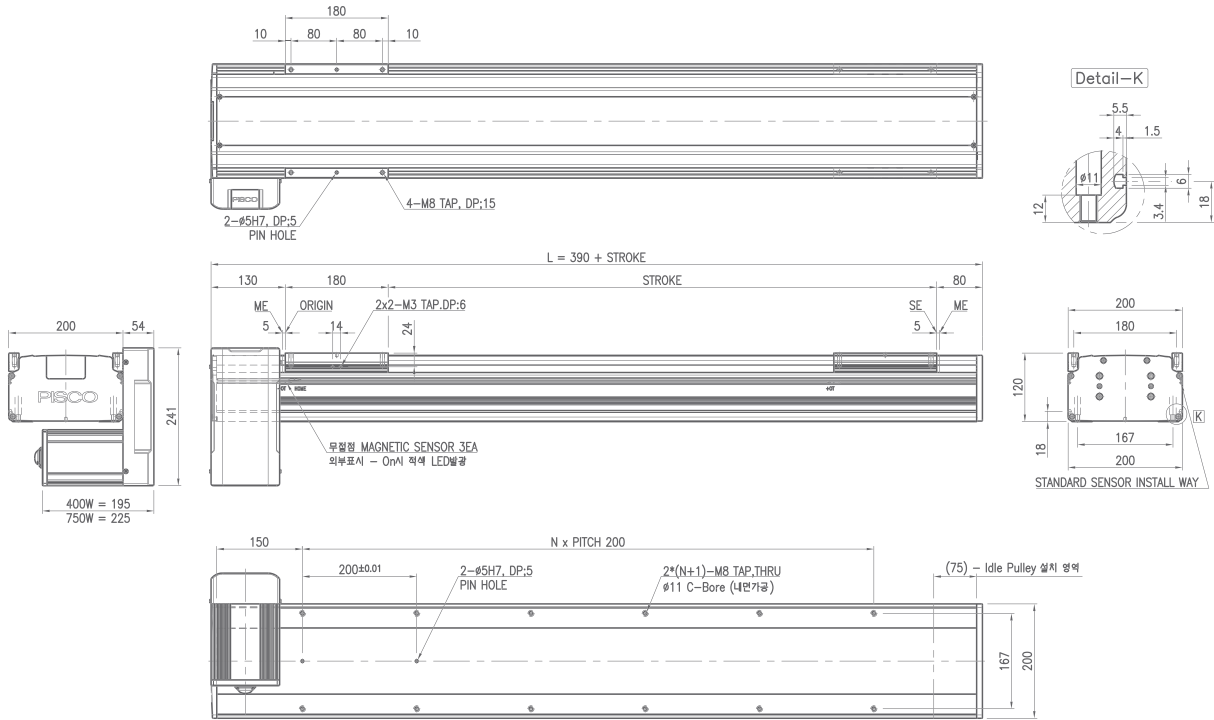

PHRB200-UR2-40(75)

